

NWZ-E353/E354/E355

SERVICE MANUAL

Ver. 1.1 2010.09



Photo: NWZ-E353

US Model
AEP Model
NWZ-E353/E354

Canadian Model
NWZ-E353/E354/E355

East European Model
South African Model

Indian Model
NWZ-E353

Note:

Be sure to keep your PC used for service and checking of this unit always updated with the latest version of your anti-virus software. In case a virus affected unit was found during service, contact your Service Headquarters.

SPECIFICATIONS

Supported file format

Music (including podcasts (*1))		
Audio Formats (Codec)	MP3	Media File format: MP3 (MPEG-1 Layer3) file format File extension: .mp3 Bit rate: 32 to 320 kbps (Supports variable bit rate (VBR)) Sampling frequency (*2): 32, 44.1, 48 kHz
	WMA	Media File format: ASF file format File extension: .wma Bit rate: 32 to 192 kbps (Supports variable bit rate (VBR)) Sampling frequency (*2): 44.1 kHz * Compatible with WM-DRM 10
	AAC-LC (*3)	Media File format: MP4 file format File extension: .mp4, .m4a, .3gp Bit rate: 16 to 320 kbps (Supports variable bit rate (VBR)) (*4) Sampling frequency (*2): 8, 11, 025, 12, 16, 22, 05, 24, 32, 44.1, 48 kHz
	Linear PCM	Media File format: Wave-Riff file format File extension: .wav Bit rate: 1,411 kbps Sampling frequency (*2): 44.1 kHz
Video (including podcasts (*1))		
Video Formats (Codec)		Frame rate: Max. 30 fps Resolution: Max. 720 × 480 (*5)
	Windows Media Video 9 (*6)	Media File format: ASF file format File extension: .wmv Profile: VC1 simple profile, main profile Bit rate: Max. 6 Mbps
Audio Formats (Codec)	WMA (for Windows Media Video 9)	Bit rate: 32 to 192 kbps (Supports variable bit rate (VBR)) Sampling frequency (*2): 44.1 kHz * Compatible with WM-DRM 10
File size		Max. 4 GB
The number of files		Max. 2,000
Photo (*7)		
Photo Format (Codec)	JPEG	Media File format: Compatible with DCF 2.0/Exif 2.21 file format File extension: .jpg Profile: Baseline Profile Number of pixels: Max. 4,096 × 4,096 pixels (16,000,000 pixels)
The number of files		Max. 20,000

(*1) The maximum recordable number of podcasts is 20,000.

(*2) Sampling frequency may not correspond to all encoders.

(*3) Copyright protected AAC-LC files cannot be played back.

(*4) Non-standard bit rates or non-guaranteed bit rates are included depending on the sampling frequency.

(*5) These numbers indicate the maximum resolution of playable video, and do not indicate the player's display resolution. The display resolution is 320 × 240.

(*6) Some WMV files can be played back only by transferring using Windows Media Player.

(*7) Some photo files cannot be played back, depending on their file formats.

Maximum recordable number of songs and time (Approx.)

The approximate times are based on the case in which you transfer or record only 4 minute songs (not including videos and photos) in the MP3 format. Other playable audio file format song numbers and times may differ from MP3 format.

Bit rate	NWZ-E353		NWZ-E354		NWZ-E355	
	Number	Time	Number	Time	Number	Time
48 kbps	2,350	156 hr. 40 min.	4,950	330 hr. 00 min.	10,000	666 hr. 40 min.
64 kbps	1,750	116 hr. 40 min.	3,650	243 hr. 20 min.	7,450	496 hr. 40 min.
128 kbps	880	58 hr. 40 min.	1,800	120 hr. 00 min.	3,700	246 hr. 40 min.
256 kbps	440	29 hr. 20 min.	925	61 hr. 40 min.	1,850	123 hr. 20 min.
320 kbps	355	23 hr. 40 min.	740	49 hr. 20 min.	1,500	100 hr. 00 min.

Maximum recordable time of videos (Approx.)

The approximate recordable times are estimated in the case where only videos are transferred. The time may differ, depending on the conditions under which the player is used.

Bit rate	NWZ-E353	NWZ-E354	NWZ-E355
	Time	Time	Time
Video Format: 384 kbps Audio Format: 128 kbps	14 hr. 00 min.	29 hr. 20 min.	59 hr. 40 min.
Video Format: 768 kbps Audio Format: 128 kbps	8 hr. 00 min.	16 hr. 40 min.	34 hr. 00 min.

Maximum recordable number of photos that can be transferred (Approx.)

Max. 20,000
Recordable number of photos may be less depending on file sizes.

Maximum recordable number of playlists

Maximum transferable number of playlists: 8,192
Maximum containable number of songs in each playlist: 999

Capacity (User available capacity) (*1)

NWZ-E353: 4 GB (Approx. 3.35 GB = 3,602,874,368 bytes)
NWZ-E354: 8 GB (Approx. 6.99 GB = 7,513,210,880 bytes)
NWZ-E355: 16 GB (Approx. 14.1 GB = 15,224,635,392 bytes)
(*1) Available storage capacity of the player may vary.
A portion of the memory is used for data management functions.

Output (headphones)

Frequency response
20 to 20,000 Hz (when playing data file, single signal measurement)

FM radio

FM Frequency range
87.5 to 108.0 MHz

IF (FM)

128 kHz

– Continued on next page –

DIGITAL MEDIA PLAYER

9-889-944-02

2010I05-1

© 2010.09

Sony Corporation

Published by Sony Techno Create Corporation

SONY®

NWZ-E353/E354/E355

Antenna

Headphone cord antenna

Interface

Headphone: Stereo mini-jack
USB I/F: mini-B
Hi-Speed USB (USB 2.0 compliant)

Operating temperature

5 °C to 35 °C (41 °F to 95 °F)

Power source

- Built-in rechargeable lithium-ion battery
- USB power (from a computer via a USB connector of the player)

Charging time

USB-based charging
Approx. 3 hours (full charge), Approx. 1.5 hours (approx. 80 %)

Battery life (continuous playback)

Actual battery life may vary depending on settings. The estimated battery usage hours shown below are based on typical usage conditions with "Basic setting of battery life measurement" as shown in the table below.

Note

- Even if the player is turned off for an extended period, a small amount of battery power is still consumed.
- Battery life may vary depending on volume setting, conditions of use, and ambient temperature.

Music	
Playback at MP3 128 kbps	Approx. 50 hours
Playback at WMA 128 kbps	Approx. 50 hours
Playback at AAC-LC 128 kbps	Approx. 48 hours
Playback at Linear PCM 1,411 kbps	Approx. 56 hours
Video	
Playback at WMV 384 kbps	Approx. 10 hours
FM radio	
Receiving FM broadcasting	Approx. 20 hours

Player settings which affect battery life

	Setting	Basic setting of battery life measurement (Default setting)
[Common settings]	[Screensaver];[On/Off] (*1)	[On]
	[Screensaver];[Delay] (*2)	[30 Sec]
	[Brightness] (*3)	[3]
	[Battery Care] (*4)	[Off]
[Music settings]	[Equalizer] (*5)	[None] (*6)
	[VPT(Surround)] (*5)	[None]
	[DSEE(Sound Enhance)] (*5)	[Off]
	[Clear Stereo] (*5)	[Off]
	[Dynamic Normalizer] (*5)	[Off]
	[DPC (Speed Control)] (*7)	[Off]
	[Display Lyrics] (*8)	[On]
	[Karaoke/Language Study] (*9)	[Off]

- (*1) The [Off] setting shortens the battery life for continuous music playback by about 85% compared with the [On] setting.
 (*2) The longer the waiting time, the shorter the battery life for continuous music playback.
 (*3) The [5] setting shortens the battery life for continuous video playback by about 45% compared with the [3] setting.
 (*4) The [On] setting shortens the battery life by about 10% compared with the [Off] setting.
 (*5) Setting [Equalizer] to other than [None], [VPT(Surround)] to other than [None], [DSEE(Sound Enhance)] to [On], [Clear Stereo] to [On] and [Dynamic Normalizer] to [On] shortens the battery life for continuous music playback by about 55% compared with setting them to [None] or [Off].
 (*6) The default setting of players sold in the Latin America region is [Custom 1]. The [Custom 1] setting shortens the battery life for continuous music playback by about 20% compared with the [None] setting.
 (*7) The [x2.0] setting shortens the battery life for continuous music playback by about 70% compared with the [Off] setting.
 (*8) The [On (No Screen Off)] setting shortens the battery life for continuous music playback by about 85% compared with the [On] setting.
 (*9) The [Maximum Karaoke Mod] setting shortens the battery life for continuous music playback by about 90% compared with the [Off] setting.

Display

2-inch, TFT color display with white LED-backlight, QVGA (240 × 320 pixels), 262,144 colors

Dimensions (w/h/d, projecting parts not included)

44 × 94.7 × 9.7 mm (1 3/4 × 3 3/4 × 13/32 inches)

Dimensions (w/h/d)

44.1 × 95.2 × 10.4 mm (1 3/4 × 3 3/4 × 7/16 inches)

Mass

Approx. 58 g (2.1 oz)

Supplied items

- Headphones (1)
- USB cable (1)
- Quick Start Guide
- Software

The software is stored in the built-in flash memory of the player, and includes the following items. For details on how to install, refer to "Quick Start Guide."

- Content Transfer
- WALKMAN Guide
- User Guide, etc.

Design and specifications are subject to change without notice.

- ATRAC is trademark of Sony Corporation.
- "WALKMAN" and "WALKMAN" logo are registered trademarks of Sony Corporation.
- DSEE and CLEAR are trademarks of Sony Corporation.
- MP3 and AAC are trademarks of Sony Corporation.
- 12 TONE ANALYSIS and its logo are trademarks of Sony Corporation.
- SensMe™ and the SensMe™ logo are trademarks or registered trademarks of Sony Ericsson Mobile Communications AB.
- Microsoft, Windows, Windows Vista and Windows Media are trademarks or registered trademarks of Microsoft Corporation in the United States and/or other countries.
- MPEG Layer-3 audio coding technology and patents licensed from Fraunhofer IIS and Thomson.
- IBM and PC/AT are registered trademarks of International Business Machines Corporation.
- Apple, Macintosh and iTunes are trademarks of Apple Inc., registered in the U.S. and other countries.
- Pentium is a trademark or a registered trademark of Intel Corporation.
- This software is based in part on the work of the Independent JPEG Group.
- THIS PRODUCT IS LICENSED UNDER THE VC-1 PATENT PORTFOLIO LICENSE FOR THE PERSONAL AND NON-COMMERCIAL USE OF A CONSUMER TO (i) ENCODE VIDEO IN COMPLIANCE WITH THE VC-1 STANDARD ("VC-1 VIDEO") AND/OR (ii) DECODE VC-1 VIDEO THAT WAS ENCODED BY A CONSUMER ENGAGED IN A PERSONAL AND NON-COMMERCIAL ACTIVITY AND/OR WAS OBTAINED FROM A VIDEO PROVIDER LICENSED TO PROVIDE VC-1 VIDEO. NO LICENSE IS GRANTED OR SHALL BE IMPLIED FOR ANY OTHER USE. ADDITIONAL INFORMATION MAY BE OBTAINED FROM MPEG LA, L.L.C. SEE [HTTP://WWW.MPEGLA.COM](http://www.mpegla.com)
- All other trademarks and registered trademarks are trademarks or registered trademarks of their respective holders. In this manual, TM and ® marks are not specified.

This product is protected by certain intellectual property rights of Microsoft Corporation. Use or distribution of such technology outside of this product is prohibited without a license from Microsoft or an authorized Microsoft subsidiary.

Content providers are using the digital rights management technology for Windows Media contained in this device ("WM-DRM") to protect the integrity of their content ("Secure Content") so that their intellectual property, including copyright, in such content is not misappropriated.

This device uses WM-DRM software to play Secure Content ("WM-DRM Software"). If the security of the WM-DRM Software in this device has been compromised, owners of Secure Content ("Secure Content Owners") may request that Microsoft revoke the WM-DRM Software's right to acquire new licenses to copy, display and/or play Secure Content. Revocation does not alter the WM-DRM Software's ability to play unprotected content. A list of revoked WM-DRM Software is sent to your device whenever you download a license for Secure Content from the Internet or from a PC. Microsoft may, in conjunction with such license, also download revocation lists onto your device on behalf of Secure Content Owners.

Program © 2010 Sony Corporation
Documentation © 2010 Sony Corporation

Information on Expat
Copyright © 1998, 1999, 2000 Thai Open Source Software Center Ltd and Clark Cooper.
Copyright © 2001, 2002, 2003, 2004, 2005, 2006 Expat maintainers.

Permission is hereby granted, free of charge, to any person obtaining a copy of this software and associated documentation files (the "Software"), to deal in the Software without restriction, including without limitation the rights to use, copy, modify, merge, publish, distribute, sublicense, and/or sell copies of the Software, and to permit persons to whom the Software is furnished to do so, subject to the following conditions:

The above copyright notice and this permission notice shall be included in all copies or substantial portions of the Software.

THE SOFTWARE IS PROVIDED "AS IS", WITHOUT WARRANTY OF ANY KIND, EXPRESS OR IMPLIED, INCLUDING BUT NOT LIMITED TO THE WARRANTIES OF MERCHANTABILITY, FITNESS FOR A PARTICULAR PURPOSE AND NONINFRINGEMENT. IN NO EVENT SHALL THE AUTHORS OR COPYRIGHT HOLDERS BE LIABLE FOR ANY CLAIM, DAMAGES OR OTHER LIABILITY, WHETHER IN AN ACTION OF CONTRACT, TORT OR OTHERWISE, ARISING FROM, OUT OF OR IN CONNECTION WITH THE SOFTWARE OR THE USE OR OTHER DEALINGS IN THE SOFTWARE.

Information on ncurses
Copyright (c) 1998-2004, 2006 Free Software Foundation, Inc.

Permission is hereby granted, free of charge, to any person obtaining a copy of this software and associated documentation files (the "Software"), to deal in the Software without restriction, including without limitation the rights to use, copy, modify, merge, publish, distribute, sublicense, and/or sell copies of the Software, and to permit persons to whom the Software is furnished to do so, subject to the following conditions:

The above copyright notice and this permission notice shall be included in all copies or substantial portions of the Software.

THE SOFTWARE IS PROVIDED "AS IS", WITHOUT WARRANTY OF ANY KIND, EXPRESS OR IMPLIED, INCLUDING BUT NOT LIMITED TO THE WARRANTIES OF MERCHANTABILITY, FITNESS FOR A PARTICULAR PURPOSE AND NONINFRINGEMENT. IN NO EVENT SHALL THE ABOVE COPYRIGHT HOLDERS BE LIABLE FOR ANY CLAIM, DAMAGES OR OTHER LIABILITY, WHETHER IN AN ACTION OF CONTRACT, TORT OR OTHERWISE, ARISING FROM, OUT OF OR IN CONNECTION WITH THE SOFTWARE OR THE USE OR OTHER DEALINGS IN THE SOFTWARE.

Except as contained in this notice, the name(s) of the above copyright holders shall not be used in advertising or otherwise to promote the sale, use or other dealings in this Software without prior written authorization.

Information on nekit-fp
Copyright (c) 1985, 1989 Regents of the University of California.
All rights reserved.

Redistribution and use in source and binary forms, with or without modification, are permitted provided that the following conditions are met:

1. Redistributions of source code must retain the above copyright notice, this list of conditions and the following disclaimer.
2. Redistributions in binary form must reproduce the above copyright notice, this list of conditions and the following disclaimer in the documentation and/or other materials provided with the distribution.
3. All advertising materials mentioning features or use of this software must display the following acknowledgment:

This product includes software developed by the University of California, Berkeley and its contributors.
4. Neither the name of the University nor the names of its contributors may be used to endorse or promote products derived from this software without specific prior written permission.

THIS SOFTWARE IS PROVIDED BY THE REGENTS AND CONTRIBUTORS "AS IS" AND ANY EXPRESS OR IMPLIED WARRANTIES, INCLUDING, BUT NOT LIMITED TO, THE IMPLIED WARRANTIES OF MERCHANTABILITY AND FITNESS FOR A PARTICULAR PURPOSE ARE DISCLAIMED. IN NO EVENT SHALL THE REGENTS OR CONTRIBUTORS BE LIABLE FOR ANY DIRECT, INDIRECT, INCIDENTAL, SPECIAL, EXEMPLARY, OR CONSEQUENTIAL DAMAGES (INCLUDING, BUT NOT LIMITED TO, PROCUREMENT OF SUBSTITUTE GOODS OR SERVICES; LOSS OF USE, DATA, OR PROFITS; OR BUSINESS INTERRUPTION) HOWEVER CAUSED AND ON ANY THEORY OF LIABILITY, WHETHER IN CONTRACT, STRICT LIABILITY, OR TORT (INCLUDING NEGLIGENCE OR OTHERWISE) ARISING IN ANY WAY OUT OF THE USE OF THIS SOFTWARE, EVEN IF ADVISED OF THE POSSIBILITY OF SUCH DAMAGE.

Information on strace
Copyright (c) 1991, 1992 Paul Kranenburg <pk@cs.feweur.nl>
Copyright (c) 1993 Branko Lankester <branko@hacktic.nl>
Copyright (c) 1993 Ulrich Pegelow <pegelow@moorea.uni-muenster.de>
Copyright (c) 1995, 1996 Michael Elizabeth Chastain <mec@duracof.shout.net>
Copyright (c) 1993, 1994, 1995, 1996 Rick Sladkey <rjs@world.std.com>
Copyright (c) 1998-2001 Wichert Akkerman <wakkerma@dehackmode.org>
All rights reserved.

Redistribution and use in source and binary forms, with or without modification, are permitted provided that the following conditions are met:

1. Redistributions of source code must retain the above copyright notice, this list of conditions and the following disclaimer.
2. Redistributions in binary form must reproduce the above copyright notice, this list of conditions and the following disclaimer in the documentation and/or other materials provided with the distribution.
3. The name of the author may not be used to endorse or promote products derived from this software without specific prior written permission.

THIS SOFTWARE IS PROVIDED BY THE AUTHOR "AS IS" AND ANY EXPRESS OR IMPLIED WARRANTIES, INCLUDING, BUT NOT LIMITED TO, THE IMPLIED WARRANTIES OF MERCHANTABILITY AND FITNESS FOR A PARTICULAR PURPOSE ARE DISCLAIMED. IN NO EVENT SHALL THE AUTHOR BE LIABLE FOR ANY DIRECT, INDIRECT, INCIDENTAL, SPECIAL, EXEMPLARY, OR CONSEQUENTIAL DAMAGES (INCLUDING, BUT NOT LIMITED TO, PROCUREMENT OF SUBSTITUTE GOODS OR SERVICES; LOSS OF USE, DATA, OR PROFITS; OR BUSINESS INTERRUPTION) HOWEVER CAUSED AND ON ANY THEORY OF LIABILITY, WHETHER IN CONTRACT, STRICT LIABILITY, OR TORT (INCLUDING NEGLIGENCE OR OTHERWISE) ARISING IN ANY WAY OUT OF THE USE OF THIS SOFTWARE, EVEN IF ADVISED OF THE POSSIBILITY OF SUCH DAMAGE.

NWZ-E353/E354/E355

SECTION 1

SERVICING NOTES

TABLE OF CONTENTS

1.	SERVICING NOTES	3
2.	DISASSEMBLY	
2-1.	Disassembly Flow.....	6
2-2.	Case (Rear) Block.....	7
2-3.	Case (Front).....	8
2-4.	Open The Short-land.....	9
2-5.	EMMC Board	9
2-6.	Support (M).....	10
2-7.	3Pin HP Jack Block.....	10
2-8.	LCD Assy (LCD1).....	11
2-9.	MOTHER Board.....	12
2-10.	VOL Key Assy.....	13
2-11.	Battery Assy (BAT1).....	13
3.	TEST MODE	14
4.	EXPLODED VIEWS	
4-1.	Case (Rear) Section	24
4-2.	Case (Front) Section	25
4-3.	LCD, Battery Section.....	26
4-4.	Chassis Section	27
5.	ACCESSORIES	28

FLEXIBLE CIRCUIT BOARD REPAIRING

- Keep the temperature of soldering iron around 270 °C during repairing.
- Do not touch the soldering iron on the same conductor of the circuit board (within 3 times).
- Be careful not to apply force on the conductor when soldering or unsoldering.

SAFETY-RELATED COMPONENT WARNING!

COMPONENTS IDENTIFIED BY MARK Δ OR DOTTED LINE WITH MARK Δ ON THE SCHEMATIC DIAGRAMS AND IN THE PARTS LIST ARE CRITICAL TO SAFE OPERATION. REPLACE THESE COMPONENTS WITH SONY PARTS WHOSE PART NUMBERS APPEAR AS SHOWN IN THIS MANUAL OR IN SUPPLEMENTS PUBLISHED BY SONY.

ATTENTION AU COMPOSANT AYANT RAPPORT À LA SÉCURITÉ!

LES COMPOSANTS IDENTIFIÉS PAR UNE MARQUE Δ SUR LES DIAGRAMMES SCHÉMATIQUES ET LA LISTE DES PIÈCES SONT CRITIQUES POUR LA SÉCURITÉ DE FONCTIONNEMENT. NE REMPLACER CES COMPOSANTS QUE PAR DES PIÈCES SONY DONT LES NUMÉROS SONT DONNÉS DANS CE MANUEL OU DANS LES SUPPLÉMENTS PUBLIÉS PAR SONY.

CAUTION

Danger of explosion if battery is incorrectly replaced. Replace only with the same or equivalent type.

System requirements

- Computer
 - IBM PC/AT compatible computer preinstalled with the following Windows operating systems (*1):
 - Windows XP Home Edition (*2) (Service Pack 3 or later)
 - Windows XP Professional (*2) (Service Pack 3 or later)
 - Windows Vista Home Basic (Service Pack 1 or later)
 - Windows Vista Home Premium (Service Pack 1 or later)
 - Windows Vista Business (Service Pack 1 or later)
 - Windows Vista Ultimate (Service Pack 1 or later)
 - Windows 7 Home Basic
 - Windows 7 Home Premium
 - Windows 7 Professional
 - Windows 7 Ultimate

Not supported by OSs other than above.

[Compatibility mode] for Windows XP (included with Windows Vista and Windows 7) is not supported.

(*1) Excluding OS Versions not supported by Microsoft.

(*2) Excluding 64-bit OS versions.

- CPU: Pentium III 450 MHz or higher for Windows XP, Pentium III 800 MHz or higher for Windows Vista, Pentium III 1 GHz or higher for Windows 7
- RAM: 256 MB or more for Windows XP, 512 MB or more for Windows Vista, 1 GB or more for Windows 7 32-bit versions, 2 GB or more for Windows 7 64-bit versions
- Hard Disk Drive: 600 MB or more of available space
- Display:
 - Screen Resolution: 800 × 600 pixels (or higher) (recommended 1,024 × 768 or higher)
 - Colors: 8 bit or higher (16 bit recommended)
- CD-ROM drive (supporting Digital Music CD playback capabilities using WDM)
- Sound card
- USB connector (Hi-Speed USB is recommended)
- Windows Media Player 11 for Windows XP and Windows Vista, Windows Media Player 12 for Windows 7
- Internet Explorer 7 or later
- Broadband Internet connection is required to use Electronic Music Distribution (EMD) or to visit the web site.

We do not guarantee operation for all computers even if they meet the above System Requirements.

Not supported by the following environments:

- Personally constructed computers or operating systems
- An environment that is an upgrade of the original manufacturer-installed operating system
- Multi-boot environment
- Multi-monitor environment
- Macintosh

Design and specifications are subject to change without notice.

ABOUT THE REPAIRING OF BOARD

When electric parts installed by this machine are defective, replace the entire board.

Individual electrical parts that the mount is done cannot be exchanged.

ABOUT THE HANDLING OF THE BATTERY ASSY (BAT1)

When the battery assy (BAT1) is removed, insulate the end of wire by a tape etc. to prevent short-circuited of the wire part of battery assy (BAT1).

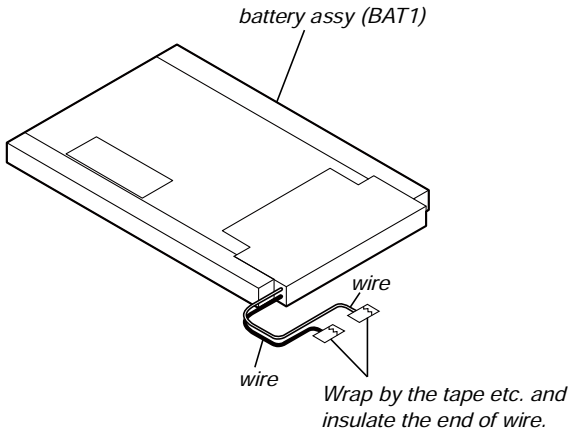

NOTE THE COMPLETE EMMC BOARD REPLACING

When the complete EMMC board is replaced, process it according to the following.

1. Destination setting

1-1. Outline

The destination code corresponding to each region must be installed into the EMMC board with the destination setting tool.

• EMMC board

Model	Capacity	Part No. of complete EMMC board	Pre-installed destination code
NWZ-E353	4GB	9-885-147-27	CEW
NWZ-E354	8GB	9-885-147-28	CEW
NWZ-E355	16GB	9-885-147-29	CEW

• Destination code

Model	Area	Destination code	Remark
NWZ-E353/ E354/E355	USA	U2	
	Canada	CA	
	Europe	CEW	
		CEV	
	India	IN	
South Africa	IN		Please use the destination code, IN

1-2. Preparation

Note 1: Please use this Tool in Windows XP or later.

Note 2: Please install Windows Media Player 11 or later to make the unit recognize as MTP.

Note 3: Confirm the method of obtaining the destination setting tool to the service headquarters.

Procedure:

1. Unzip the destination setting tool to get “NWZE35XE45X_Dest_Setting” folder.
2. There are the three folders if you open “NWZE35XE45X_DEST_Setting” folder.
3. Copy the three folders in step 2 under C Drive.

Remark: Above folders in step 2 can be saved anywhere as long as the folder path is with English (one byte character).
Described with the example that “the folders were saved under C Drive” on this service manual.

One point: The destination setting tool for each series is stored as below.

Folder name	Folder name	Updater files
NWZ-E35X	WMT_CA	updating-mtp.bat etc.
	WMT_CEV	updating-mtp.bat etc.
	WMT_CEW	updating-mtp.bat etc.
	WMT_IN	updating-mtp.bat etc.
	WMT_U2	updating-mtp.bat etc.

1-3. How to use the destination setting tool

Note 1: Please use this tool after closing other application software.

Will be described with below conditions as an example.

Model: NWZ-E353/E354/E355

Destination: CEW

Procedure:

1. Turn on power of the WALKMAN, and connect it to PC.
2. Start the command prompt application software, and change the folder pass to your desired folder (Example: c:\NWZE35X\WMT_CEW).

```
C:\>cd c:\NWZE35X\WMT_CEW
C:\NWZE35X\WMT_CEW>
```

3. Input “updating-mtp” and press the Enter key on PC.

```
C:\NWZE35X\WMT_CEW>updating-mtp
```

4. If the following message is displayed, input “y” and press the Enter key on PC.

Note 2: When the Enter key on PC is pressed, the WALKMAN is formatted.

```
*** MTP F/W Update will start.
*** The WALKMAN unit reboots automatically after updating.
*** Before starting this program, close other application such as WMP, Napster and Rhapsody etc.
*** Does this program run? (y/n)y
```

MTP F/W Update will start.
The WALKMAN unit reboots automatically after updating.
Before starting this program, close other application such as WMP, Napster and Rhapsody etc.
Does this program run? (y/n)

5. The following message is displayed. Then, destination setting operation starts.

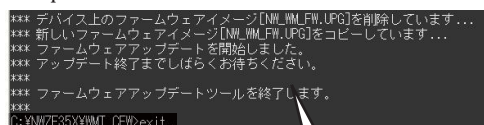

*F/W Updating starts.
Please wait for a while until updating is completed.*

6. The WALKMAN reboots automatically after the destination data is updated. After rebooting, check that connecting USB (MTP) is displayed on the liquid crystal display of the WALKMAN.
7. Input "EXIT" to close the command prompt application software.
8. Disconnect the WALKMAN from PC.
9. Turn the power on of the WALKMAN.
10. Press the [BACK] key for more 1.5 seconds, the home menu is displayed.
11. Slide the [HOLD] key from OFF to ON.
12. Press the key as following order.
▶ → ◀ → [VOL +] → [VOL -] → ▶ → ◀ → [OPTION] → [BACK] → [OPTION] → [BACK]
13. The WALKMAN reboots and the color bar is displayed on the liquid crystal display.
14. Enter the test mode when any keys are pressed in the state of step 13, and slide the [HOLD] key from ON to OFF.
15. Press the [▲]/[▼] keys to select the "OTHER", and press the ▶ key to enter the minor item.
16. Press the [▲]/[▼] keys to select the "DEST".
17. Press the ▶ key, and check if the destination is updated properly.

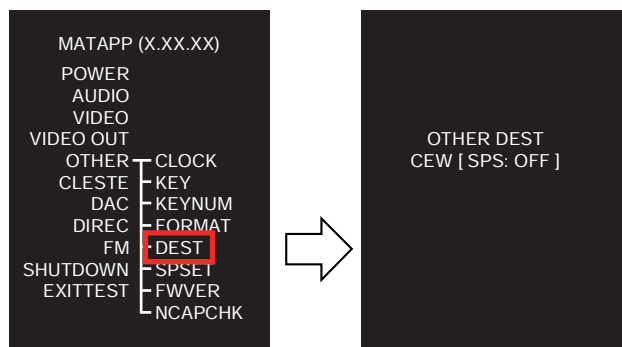

18. Press the [BACK] key twice, return to major item selection screen.
19. Press the [▲]/[▼] keys to select the "EXITTEST", and press the ▶ key to select the "SURE ?".
20. Press the ▶ key, turn the power off and release the test mode.

Note: Execute "Reset all settings" absolutely at the end (Refer to "3. Reset all setting").

2. Format Formatting memory [Format]

You can format the built-in flash memory of the player.

Note:

- If the memory is formatted, all data (songs, videos, photos, etc., including sample data installed at the factory, bundled software installer, and the User Guide) will be erased. Be sure to verify the data stored in memory prior to formatting, and export any important data to the hard disk of your computer.
- Be sure not to initialize (format) the built-in flash memory of the player using Windows Explorer. If you have formatted with Windows Explorer, format again using the player.

1. From the Home menu, select [Settings] → [Common Settings] → [Reset/Format] → [Format].
[All data including songs will be deleted. Proceed?] appears.
2. Select [Yes].
[All data will be deleted. Proceed?] appears.
To cancel the operation, select [No].
3. Select [Yes].
When initialization finishes, [Memory formatted.] appears.
To cancel the operation, select [No].

3. Reset all setting Returning to the factory settings [Reset All Settings]

You can reset the player to the default settings. Resetting the player will not delete data such as music, video, and photos.

Note:

- If you select this function during playback, the player will pause playback before performing the reset process.

1. From the Home menu, select [Settings] , [Common Settings] , [Reset/Format] , [Reset All Settings] , [Yes].
[Restored factory settings.] appears.
- To cancel the operation, select [No] on the confirmation screen.

4. Wallpapers setting

How to install the wallpaper files into the WALKMAN.

Note: Confirm the method of obtaining the wallpaper files to the service headquarters.

Procedure:

1. Unzip the wallpaper files to get the following files (jpeg file).

Folder name: WALLPAPERS

- W001.jpg
- W002.jpg
- W003.jpg

2. Connect the WALKMAN to PC.
3. Start up windows explorer. Then, open [WALKMAN] - [StorageMedia].
4. Open "PICTURE" folder located under "StorageMedia" folder.
5. Copy the "WALLPAPERS" folder in step 2 under the "PICTURE" folder.

COLOR VARIATION

Model	Destination	Color		
		Black	Red	Blue
NWZ-E353	US	●	●	●
	Canadian	●	-	-
	AEP	●	●	-
	East European	●	-	-
	South African	●	●	-
	Indian	●	●	-
NWZ-E354	US	●	●	●
	Canadian	●	●	●
	AEP	●	●	-
NWZ-E355	Canadian	●	●	●

SECTION 2 DISASSEMBLY

- This set can be disassembled in the order shown below.

2-1. DISASSEMBLY FLOW

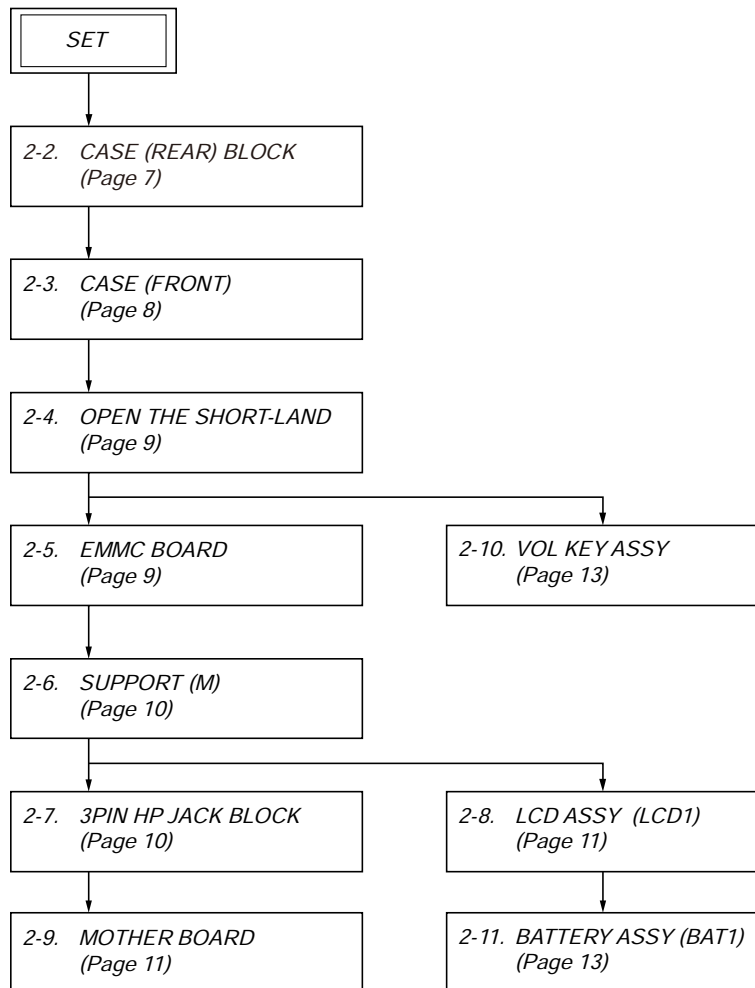

Note: Follow the disassembly procedure in the numerical order given.

2-2. CASE (REAR) BLOCK

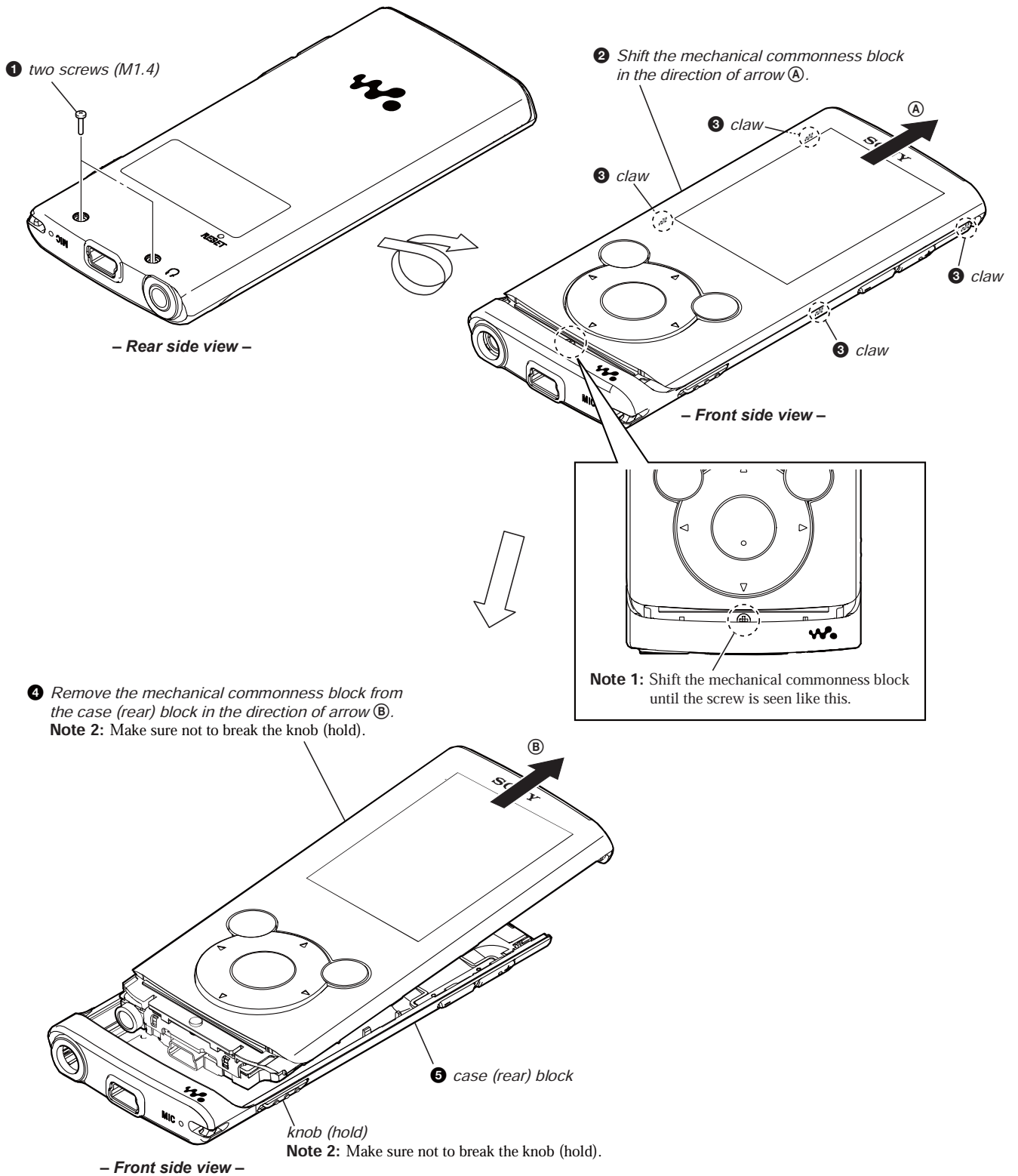

2-3. CASE (FRONT)

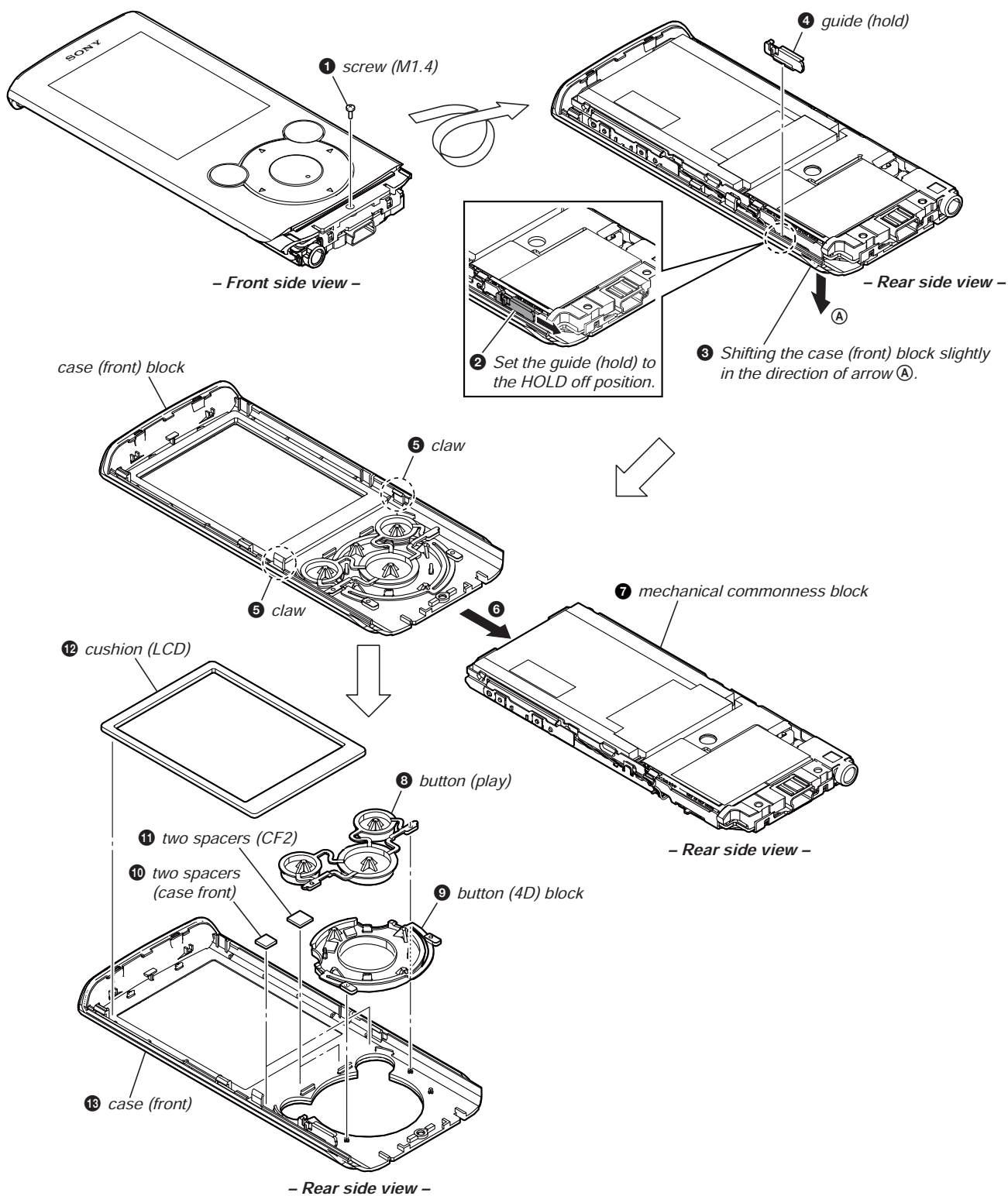

2-4. OPEN THE SHORT-LAND

Note 1: This illustration sees the mechanical commonness block from LCD assy side.

Note 2: Make sure to remove one solder to become an open state before disassembling the mechanical commonness block.

Note 3: Solder the short-land after all wirings are connected when you exchanged some mounted board.

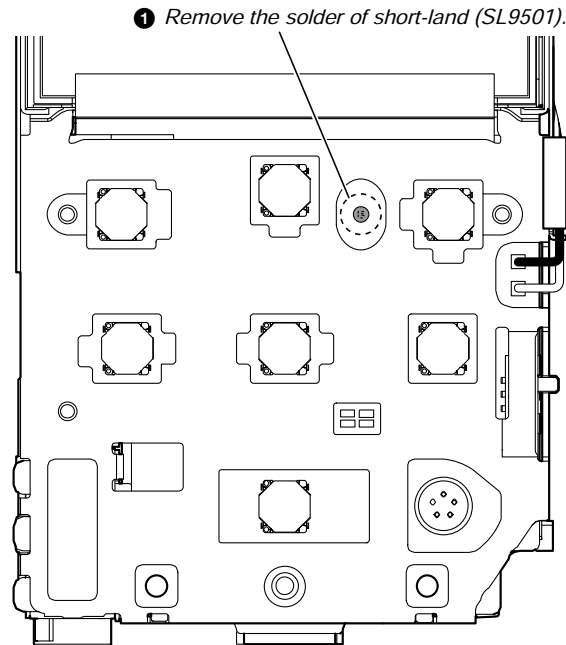

2-5. EMMC BOARD

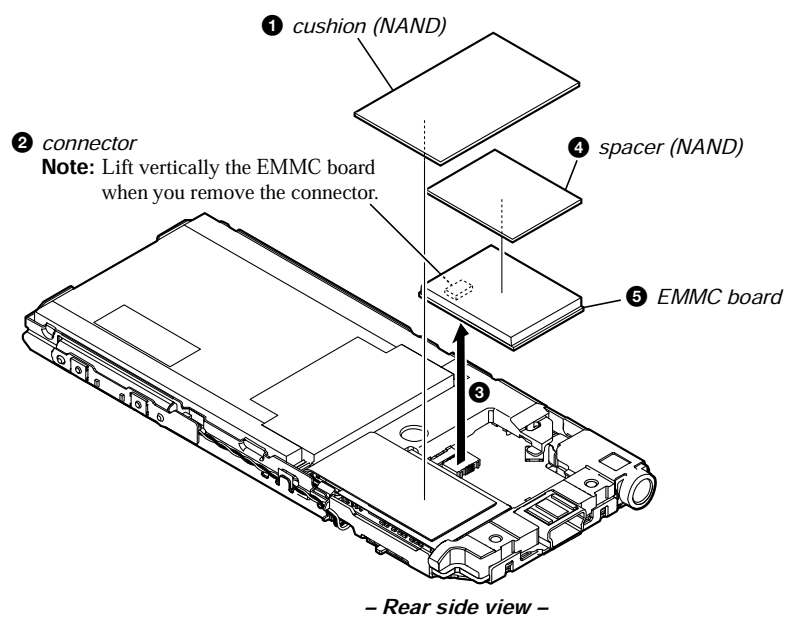

2-6. SUPPORT (M)

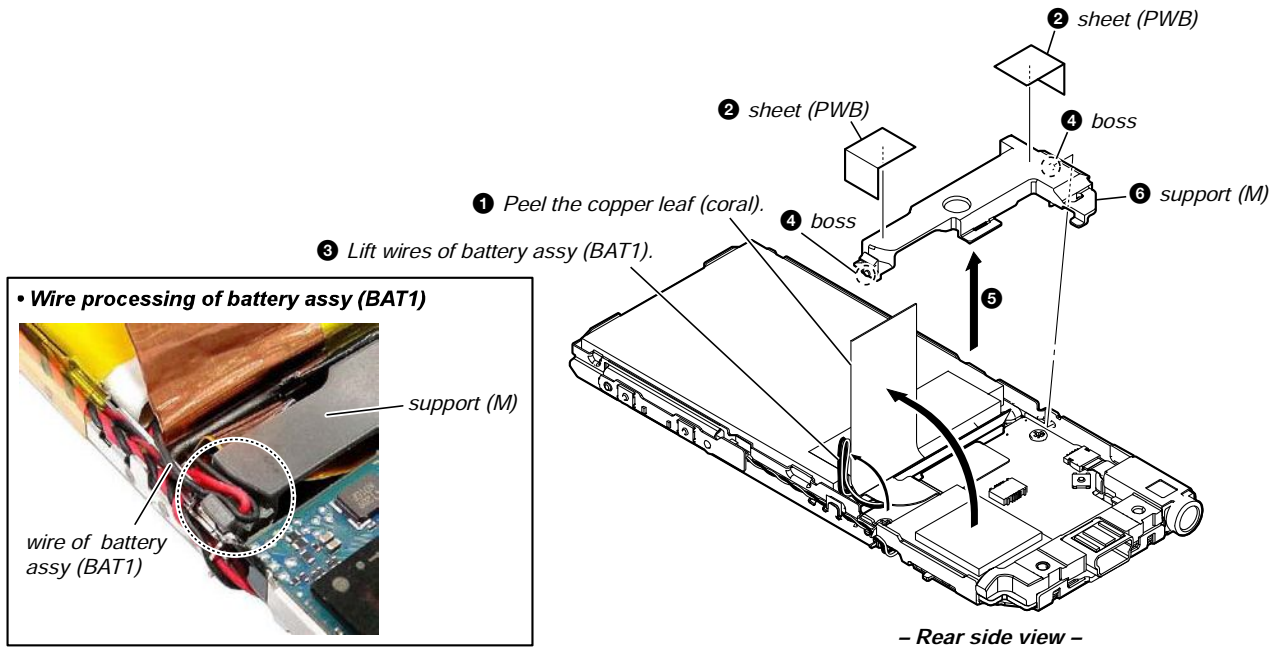

2-7. 3PIN HP JACK BLOCK

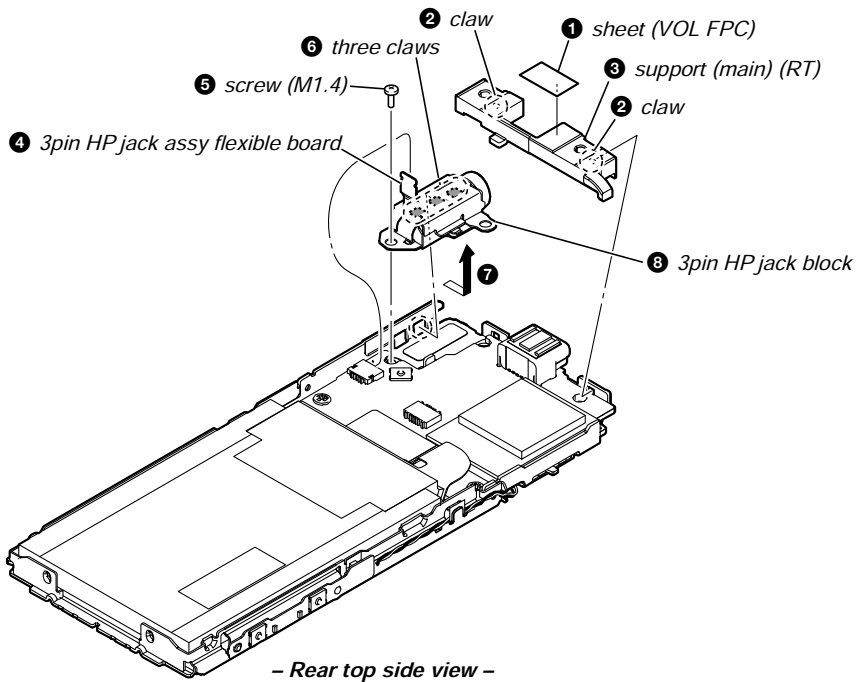

2-8. LCD ASSY (LCD1)

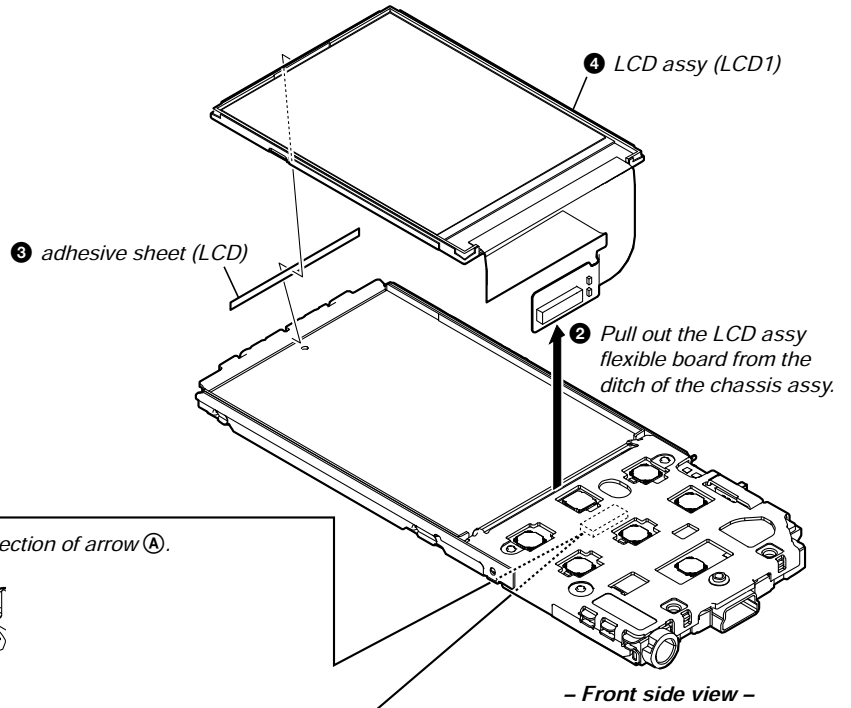

① Remove the LCD assy flexible board in the direction of arrow (A).

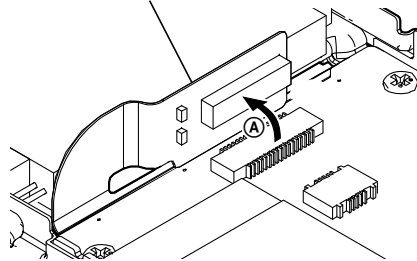

Note 1: There is a possibility of damaging LCD assy flexible board when removing excluding the direction of arrow (A).



Note 2: Please match the position of two ditches and two ribs when you install LCD assy flexible board.
If putting into the connector shift ditch and rib, connector will be broken.

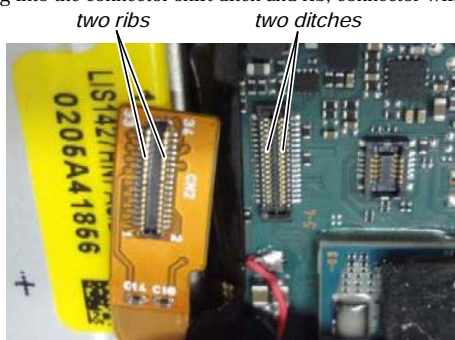

2-9. MOTHER BOARD

② Remove two solders of battery assy (BAT1).

Note 1: When the battery assy (BAT1) is removed, refer to "ABOUT THE HANDLING OF THE BATTERY ASSY (BAT1)" (page 4).

• Wire processing of battery assy (BAT1)

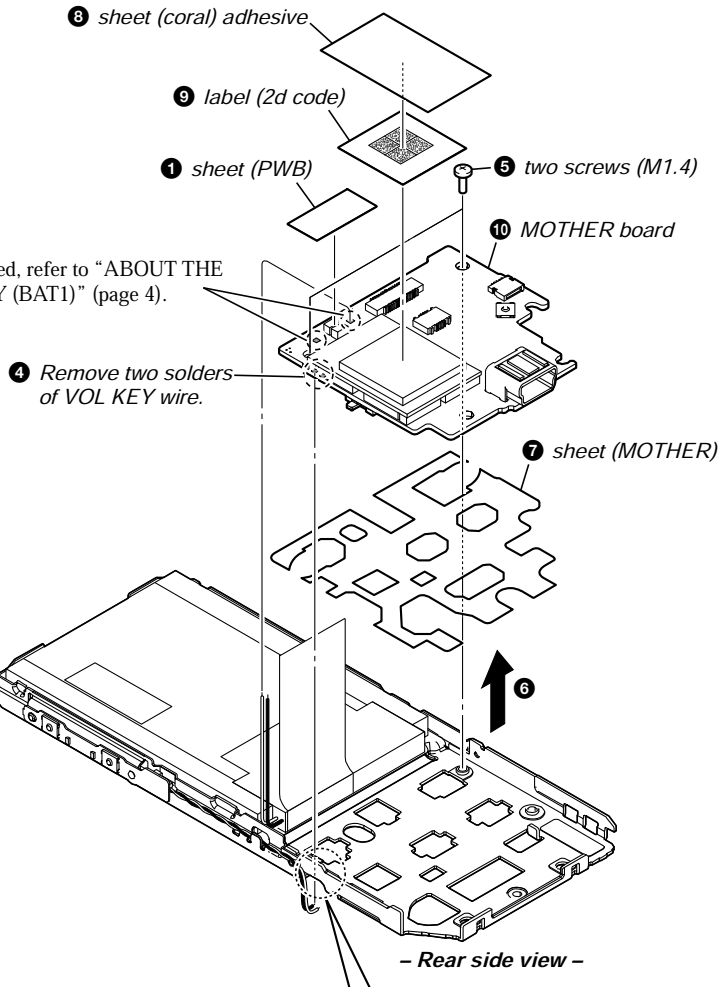
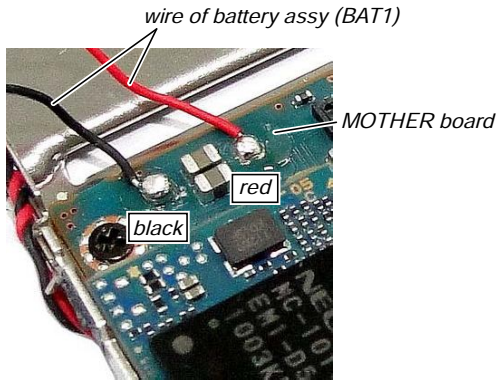

④ Remove two solders of VOL KEY wire.

• Wire processing of VOL key wire
- Front side view -

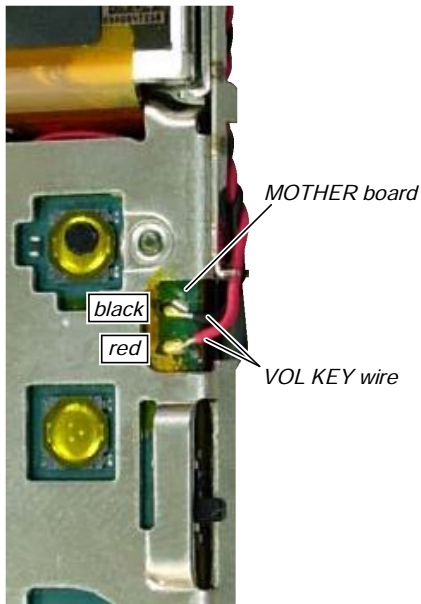

③ Cut and peel off the sheet (MOTHER).

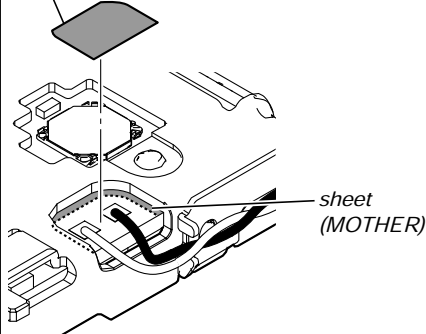

Note 2: When assembling, please paste the polyimide sheet by using the following part and make the size, Approx. 3 mm × 4 mm.

Part No. : 9-913-402-43
Description : polyimide sheet, t=0.075

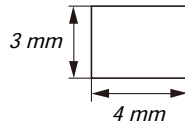

2-10. VOL KEY ASSY

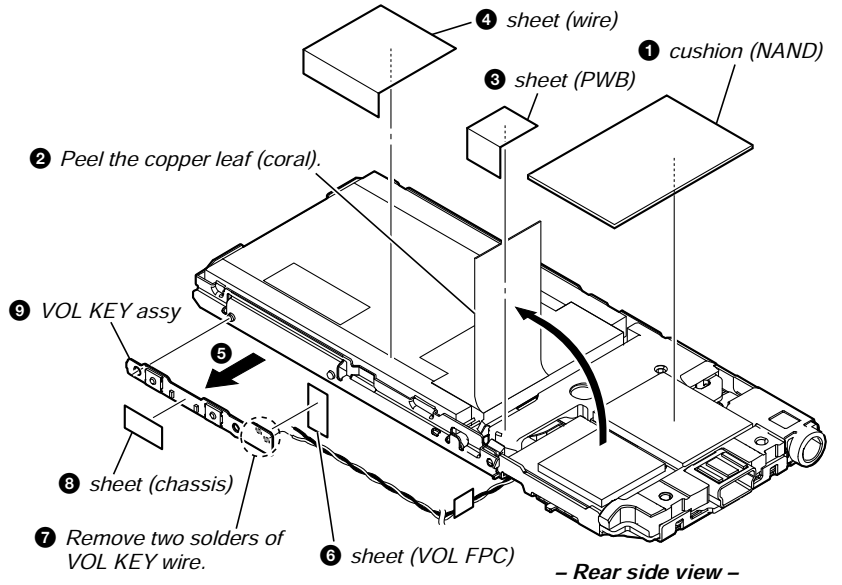
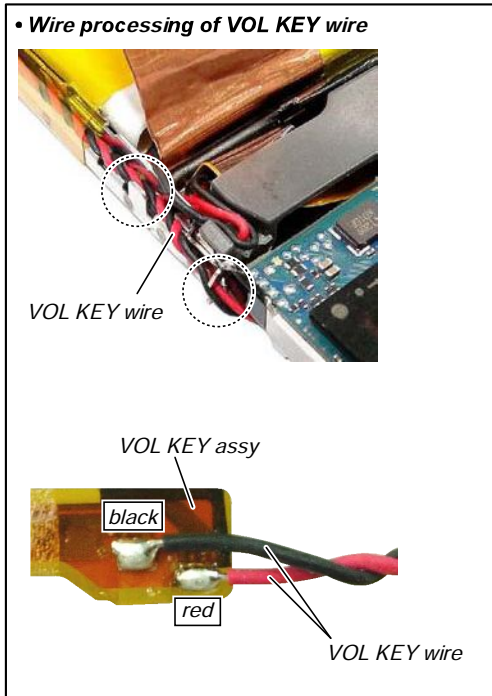

2-11. BATTERY ASSY (BAT1)

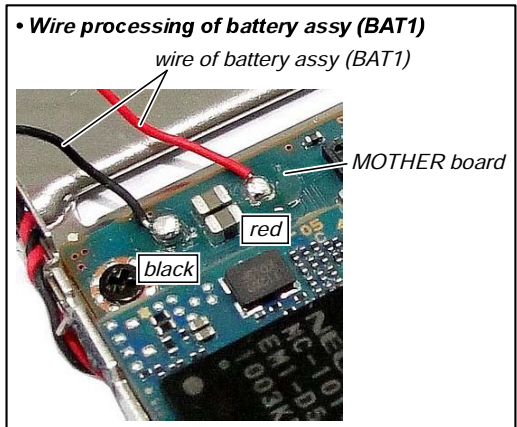
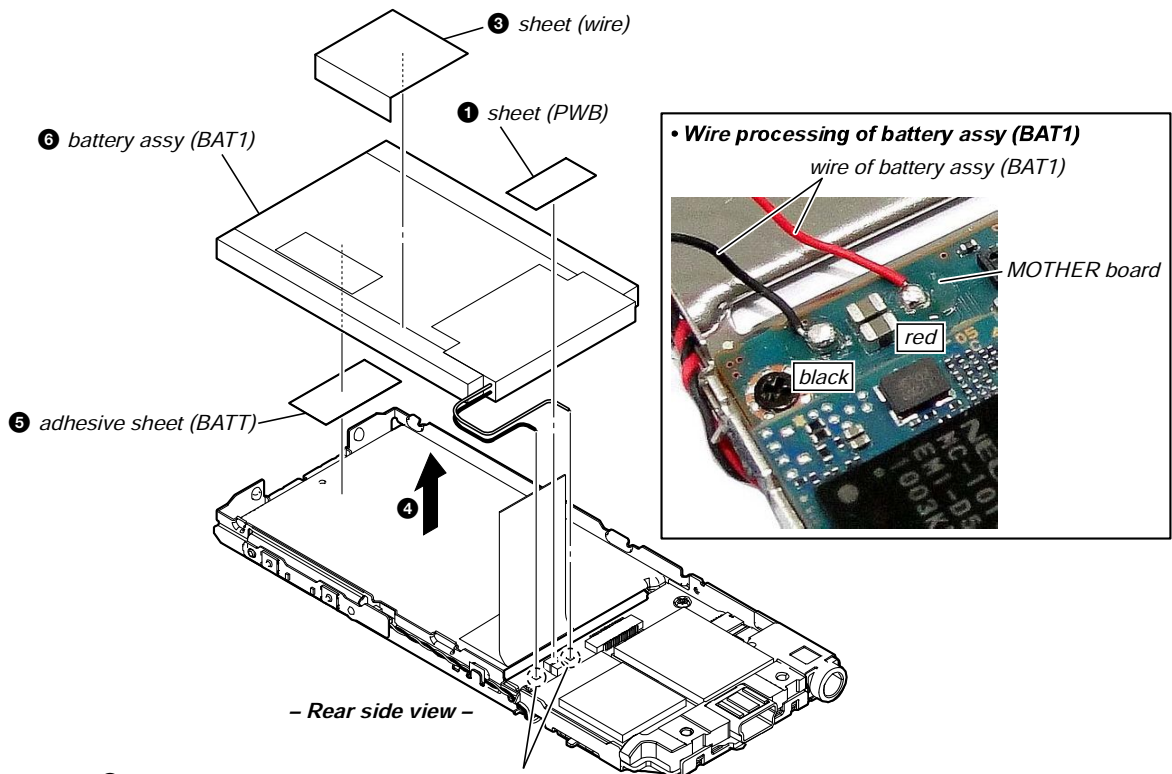

Note 2: When the battery assy (BAT1) is removed, refer to "ABOUT THE HANDLING OF THE BATTERY ASSY (BAT1)" (page 4).

SECTION 3 TEST MODE

Note 1: Information on the test mode must correspond in enough security. When the leakage has been revealed by any chance, the source of information is specified.

Note 2: Execute "EXITTEST" when you release the test mode.

1. SETTING THE TEST MODE

Note: Perform the test mode in the state of 3.6 V or more in the battery voltage.

Setting method:

1. Turn the power on.
2. Press the [BACK] key for more 1.5 seconds, the home menu is displayed.
3. Slide the [HOLD] key from OFF to ON.
4. Press the key as following order:
[▶] → [◀] → [VOL +] → [VOL -] → [▶] → [◀] → [OPTION] → [BACK] → [OPTION] → [BACK]
5. The set reboots and the color bar is displayed on the liquid crystal display.
6. Enter the test mode when any keys are pressed in the state of step 5, and slide the [HOLD] key from ON to OFF.

Note: The destination setting and sound pressure regulation setting cannot be executed by this test mode.

2. RELEASING THE TEST MODE

1. Display the major item selection screen.
2. Press the [▲]/[▼] keys to select the "EXITTEST", and press the [▶] key to select the "SURE?".
3. Press the [▶||] key, turn the power off and release the test mode.

3. CONFIGURATION OF THE TEST MODE

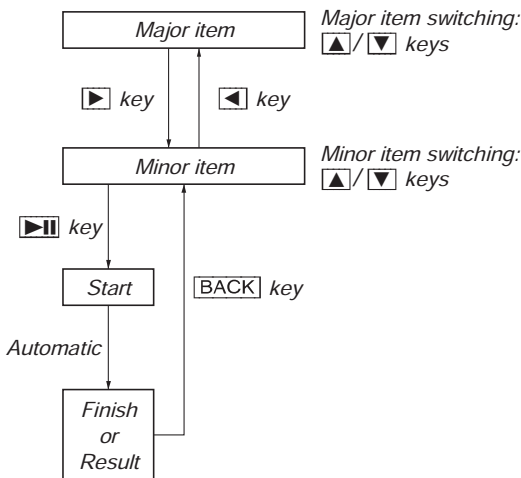

4. OPERATION OF THE TEST MODE

4-1. Power (POWER)

Screen display

MPTAPP (X.XX.XX)	
POWER	VCHK
AUDIO	ACHK
VIDEO	DSVCHK
VIDEO OUT	CHGCHK
OTHER	BATTCHK
CLESTE	RMVBATT
DAC	FORCECHG
DIREC	
FM	
SHUTDOWN	
EXITTEST	

4-1-1. Power supply voltage check (VCHK)

This mode is used in case power supply voltage in the state where all power supply lines are starting is checked.

Checking method:

1. Enter the test mode.
2. Press the [▲]/[▼] keys to select the "POWER", and press the [▶] key to enter the minor item.
3. Press the [▲]/[▼] keys to select the "VCHK".
4. Press the [▶||] key, all power supply lines are started.

Screen display

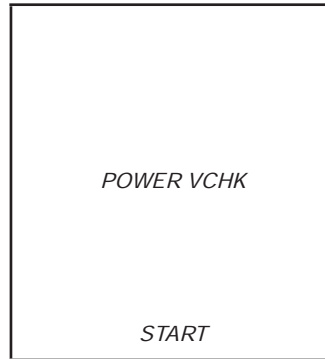

In this state, the power supply voltage of each power supply line can be confirmed by measuring the voltage.

5. Press the [BACK] key, return to minor item selection screen.

4-1-2. Consumption current (audio playback) check (ACHK)

This mode is used in case consumption current (audio playback) is checked in the state where "1 kHz 0 dBs L-ch/R-ch VOLUME: 15" audio signal is outputted.

Checking method:

1. Enter the test mode.
2. Press the [▲]/[▼] keys to select the "POWER", and press the [▶] key to enter the minor item.
3. Press the [▲]/[▼] keys to select the "ACHK".
4. Press the [▶||] key, "1 kHz 0 dBs L-ch/R-ch VOLUME: 15" audio signal is outputted.

Screen display

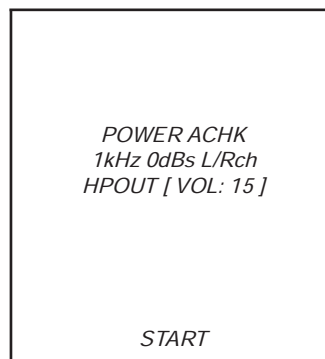

5. In this state, each time the [▶] key is pressed, LCD back light on/off switch is performed.
6. Press the [BACK] key, return to minor item selection screen.

4-1-3. Standby current check (DSVCHK)

This mode is used in case standby current is checked.

Checking method:

1. Enter the test mode.
2. Press the [▲]/[▼] keys to select the "POWER", and press the [▶] key to enter the minor item.
3. Press the [▲]/[▼] keys to select the "DSVCHK".
4. Press the [▶||] key, enter the state of the deep sleep.
5. Press the [BACK] key, release the state of the deep sleep.

Screen display

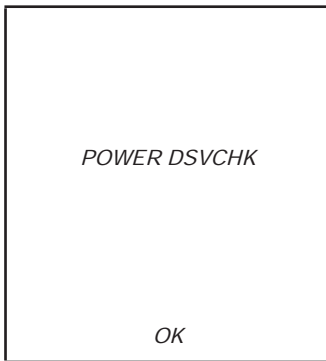

6. Press the [BACK] key, return to minor item selection screen.

4-1-4. Charge current check (CHGCHK)

This mode is used in case charge current is checked.

Checking method:

1. Enter the test mode.
2. Press the [▲]/[▼] keys to select the "POWER", and press the [▶] key to enter the minor item.
3. Press the [▲]/[▼] keys to select the "CHGCHK".
4. Press the [▶||] key, the charge setting is displayed.

Screen display

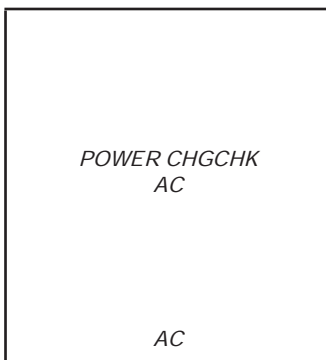

5. In this state, each time the [▶] key is pressed, the port setting for the charge is changed as shown in the table below.

	Port control		
Display	CHG_XCHGEN	CHG_PEN1	CHG_PEN2
AC	L	H	H
USB500	L	H	H
USB100	L	H	L

6. Press the [BACK] key, return to minor item selection screen.

4-1-5. Battery voltage detection check (BATTCHK)

This mode is used in case battery voltage is checked.

Checking method:

1. Enter the test mode.
2. Press the [▲]/[▼] keys to select the "POWER", and press the [▶] key to enter the minor item.
3. Press the [▲]/[▼] keys key to select the "BATTCHK".
4. Press the [▶||] key, the battery voltage is displayed.
When the battery voltage cannot be confirmed, "ERROR" is displayed.

Screen display

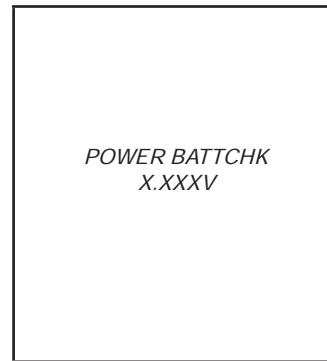

X.XXXV: Battery voltage

5. Press the [BACK] key, return to minor item selection screen.

4-1-6. Battery separation (RMVBATT)

When the battery is removed, this mode is used.

Note: Not used for the servicing.

4-1-7. Compulsion charge (FORCECHG)

When compulsorily charging a battery, this mode is used.

Note: Not used for the servicing.

4-2. Audio (AUDIO)

While playing the audio track, it's in a repeat state. If [BACK] key is pressed, it's stopped.

Press the [◀] key to switch the HPOUT/LINEOUT/SPEAKER.

Screen display

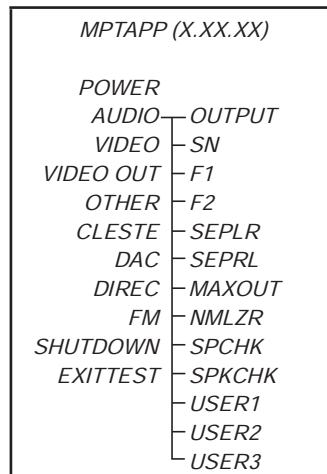

4-2-1. Output check (OUTPUT)

“1 kHz 0 dBs L-ch/R-ch VOLUME: 25” audio signal is outputted.

Checking method:

1. Enter the test mode.
2. Press the [▲]/[▼] keys to select the “AUDIO”, and press the [▶] key to enter the minor item.
3. Press the [▲]/[▼] keys to select the “OUTPUT”.
4. Press the [▶▶] key, “1 kHz 0 dBs L-ch/R-ch VOLUME: 25” audio signal is outputted.

Screen display

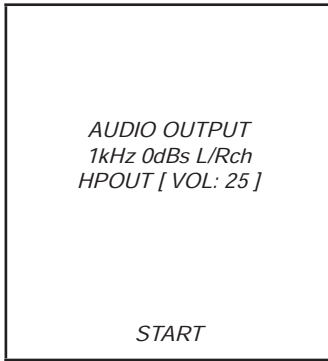

5. Press the [BACK] key, return to minor item selection screen.

4-2-2. S/N check (SN)

“Infinity Zero VOLUME: 25” audio signal is outputted.

Checking method:

1. Enter the test mode.
2. Press the [▲]/[▼] keys to select the “AUDIO”, and press the [▶] key to enter the minor item.
3. Press the [▲]/[▼] keys to select the “SN”.
4. Press the [▶▶] key, “Infinity Zero VOLUME: 25” audio signal is outputted.

Screen display

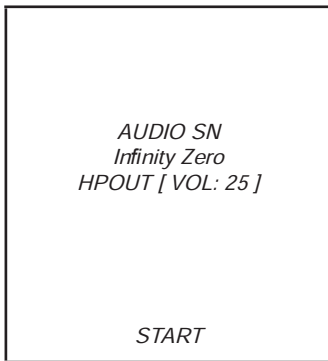

5. Press the [BACK] key, return to minor item selection screen.

4-2-3. Frequency characteristic 1 check (F1)

“20 Hz 0 dBs L-ch/R-ch VOLUME: 25” audio signal is outputted.

Checking method:

1. Enter the test mode.
2. Press the [▲]/[▼] keys to select the “AUDIO”, and press the [▶] key to enter the minor item.
3. Press the [▲]/[▼] keys to select the “F1”.
4. Press the [▶▶] key, “20 Hz 0 dBs L-ch/R-ch VOLUME: 25” audio signal is outputted.

Screen display

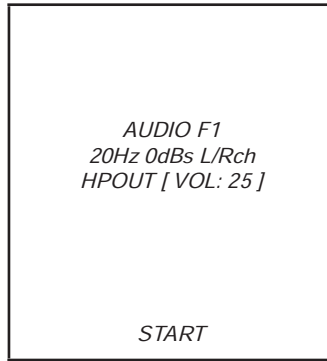

5. Press the [BACK] key, return to minor item selection screen.

4-2-4. Frequency characteristic 2 check (F2)

“20 kHz 0 dBs L-ch/R-ch VOLUME: 25” audio signal is outputted.

Checking method:

1. Enter the test mode.
2. Press the [▲]/[▼] keys to select the “AUDIO”, and press the [▶] key to enter the minor item.
3. Press the [▲]/[▼] keys to select the “F2”.
4. Press the [▶▶] key, “20 kHz 0 dBs L-ch/R-ch VOLUME: 25” audio signal is outputted.

Screen display

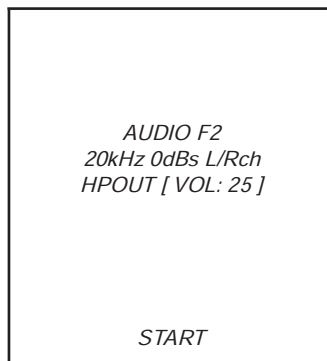

5. Press the [BACK] key, return to minor item selection screen.

4-2-5. CH separation (L-ch) check (SEPLR)

“1 kHz 0 dBs L-ch VOLUME: 25” audio signal is outputted.

Checking method:

1. Enter the test mode.
2. Press the [▲]/[▼] keys to select the “AUDIO”, and press the [▶] key to enter the minor item.
3. Press the [▲]/[▼] keys to select the “SEPLR”.
4. Press the [▶▶] key, “1 kHz 0 dBs L-ch VOLUME: 25” audio signal is outputted.

Screen display

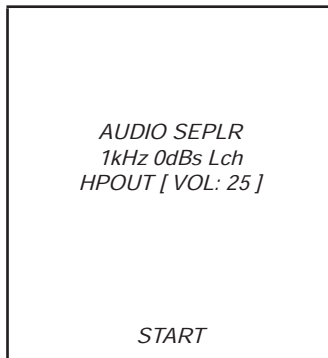

5. Press the [BACK] key, return to minor item selection screen.

4-2-6. CH separation (R-ch) check (SEPRL)

“1 kHz 0 dBs R-ch VOLUME: 25” audio signal is outputted.

Checking method:

1. Enter the test mode.
2. Press the [▲]/[▼] keys to select the “AUDIO”, and press the [▶] key to enter the minor item.
3. Press the [▲]/[▼] keys to select the “SEPRL”.
4. Press the [▶▶] key, “1 kHz 0 dBs R-ch VOLUME: 25” audio signal is outputted.

Screen display



5. Press the [BACK] key, return to minor item selection screen.

4-2-7. Maximum output check (MAXOUT)

“1 kHz 0 dBs L-ch/R-ch VOLUME: 30” (Headphone output when AVLS operates: “1 kHz 0 dBs L-ch/R-ch VOLUME: 13”) audio signal is outputted.

Checking method:

1. Enter the test mode.
2. Press the [▲]/[▼] keys to select the “AUDIO”, and press the [▶] key to enter the minor item.
3. Press the [▲]/[▼] keys to select the “MAXOUT”.
4. Press the [▶▶] key, “1 kHz 0 dBs L-ch/R-ch VOLUME: 30” (Headphone output when AVLS operates: “1 kHz 0 dBs L-ch/R-ch VOLUME: 13”) audio signal is outputted.

Screen display

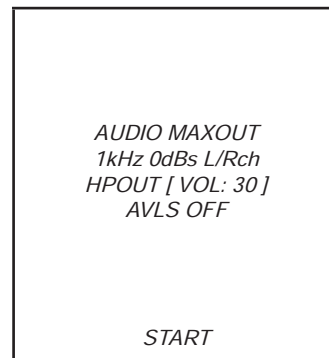

5. In this state, each time the [▶] key is pressed, AVLS on/off switch is performed.
6. Press the [BACK] key, return to minor item selection screen.

4-2-8. Normalizer check (NMLZR)

“1 kHz -24 dBs L-ch/R-ch VOLUME: 30” audio signal is outputted.

Checking method:

1. Enter the test mode.
2. Press the [▲]/[▼] keys to select the “AUDIO”, and press the [▶] key to enter the minor item.
3. Press the [▲]/[▼] keys to select the “NMLZR”.
4. Press the [▶▶] key, “1 kHz -24 dBs L-ch/R-ch VOLUME: 30” audio signal is outputted.

Screen display

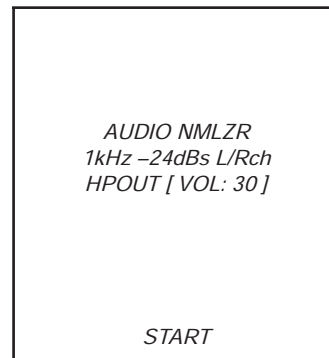

5. Press the [BACK] key, return to minor item selection screen.

4-2-9. Sound pressure regulation level check (SPCHK)
 "1 kHz 0 dBs L-ch/R-ch VOLUME: 30" audio signal is outputted.

Checking method:

1. Enter the test mode.
2. Press the [▲]/[▼] keys to select the "AUDIO", and press the [▶] key to enter the minor item.
3. Press the [▲]/[▼] keys to select the "SPCHK".
4. Press the [▶▶] key, "1 kHz 0 dBs L-ch/R-ch VOLUME: 30" audio signal is outputted.

Screen display



5. Press the [BACK] key, return to minor item selection screen.

4-2-10. Speaker check

"20 – 20kHz 0dBs L-ch/R-ch VOLUME: 30" audio signal is outputted.

Note: Not used for the servicing.

4-2-11. User specification contents playback 1 (USER1)
 "/User1.oma" is reproduced.

Checking method:

1. Enter the test mode.
2. Press the [▲]/[▼] keys to select the "AUDIO", and press the [▶] key to enter the minor item.
3. Press the [▲]/[▼] keys to select the "USER1".
4. Press the [▶▶] key, "/User1.oma" is reproduced.

Screen display

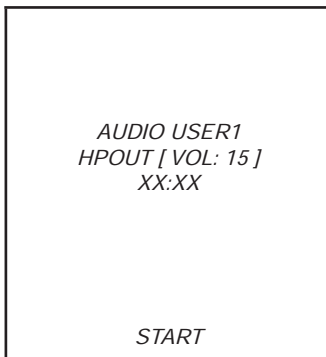

XX:XX : Repetition expert totaling time

5. Press the [BACK] key, return to minor item selection screen.

4-2-12. User specification contents playback 2 (USER2)
 "/User2.oma" is reproduced.

Checking method:

1. Enter the test mode.
2. Press the [▲]/[▼] keys to select the "AUDIO", and press the [▶] key to enter the minor item.
3. Press the [▲]/[▼] keys to select the "USER2".
4. Press the [▶▶] key, "/User2.oma" is reproduced.

Screen display

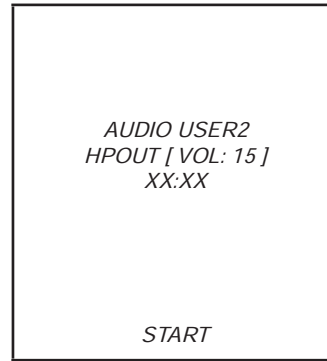

XX:XX : Repetition expert totaling time

5. Press the [BACK] key, return to minor item selection screen.

4-2-13. User specification contents playback 3 (USER3)
 "/User3.oma" is reproduced.

Checking method:

1. Enter the test mode.
2. Press the [▲]/[▼] keys to select the "AUDIO", and press the [▶] key to enter the minor item.
3. Press the [▲]/[▼] keys to select the "USER3".
4. Press the [▶▶] key, "/User3.oma" is reproduced.

Screen display

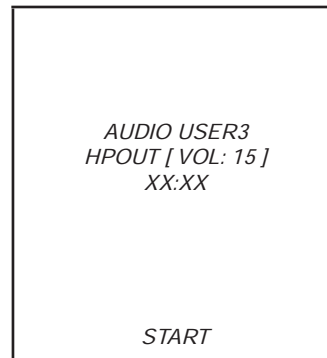

XX:XX : Repetition expert totaling time

5. Press the [BACK] key, return to minor item selection screen.

4-3. Video (VIDEO)

Screen display

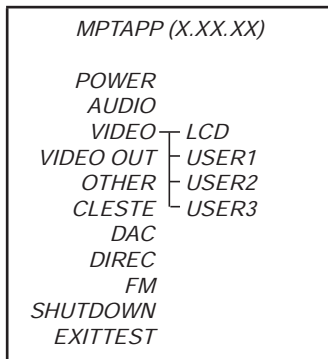

4-3-1. LCD display check (LCD)

Screen display is checked.

Checking method:

1. Enter the test mode.
2. Press the [▲]/[▼] keys to select the "VIDEO", and press the [▶] key to select the "LCD".
3. Press the [▶||] key, all black is displayed on the screen.
4. In this state, each time the [OPTION] key is pressed, the screen display changes in the following order.

All black (default) → Color bar (standard) → Color bar (brightness minimum) → Color bar (brightness maximum) → All red → All green → All blue → All white → Maximum drawing size confirmation → diagonal gradation (red) → diagonal gradation (green) → diagonal gradation (blue) → diagonal gradation (white)

Maximum drawing size confirmation:

All blue (All sides are red) is displayed. Whether red in all sides is seen is confirmed.

5. In this state, each time the [▶] key is pressed, brightness min/max/middle switch is performed.
6. Press the [BACK] key, return to minor item selection screen.

4-3-2. User specification contents playback 1 (USER1)

"/User1.mp4" is reproduced.

Checking method:

1. Enter the test mode.
2. Press the [▲]/[▼] keys to select the "VIDEO", and press the [▶] key to enter the minor item.
3. Press the [▲]/[▼] keys to select the "USER1".
4. Press the [▶||] key, "/User1.mp4" is reproduced.

Screen display

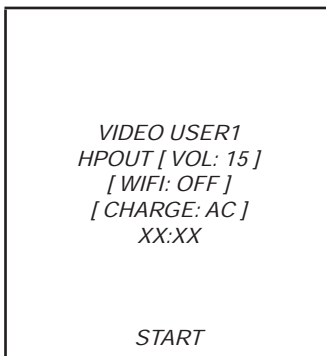

XX:XX : Repetition expert totaling time

5. Press the [BACK] key, return to minor item selection screen.

4-3-3. User specification contents playback 2 (USER2)

"/User2.mp4" is reproduced.

Checking method:

1. Enter the test mode.
2. Press the [▲]/[▼] keys to select the "VIDEO", and press the [▶] key to enter the minor item.
3. Press the [▲]/[▼] keys to select the "USER2".
4. Press the [▶||] key, "/User2.mp4" is reproduced.

Screen display

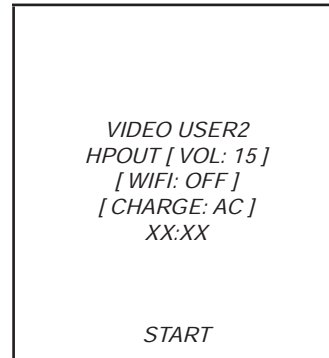

XX:XX : Repetition expert totaling time

5. Press the [BACK] key, return to minor item selection screen.

4-3-4. User specification contents playback 3 (USER3)

"/User3.mp4" is reproduced.

Checking method:

1. Enter the test mode.
2. Press the [▲]/[▼] keys to select the "VIDEO", and press the [▶] key to enter the minor item.
3. Press the [▲]/[▼] keys to select the "USER3".
4. Press the [▶||] key, "/User3.mp4" is reproduced.

Screen display

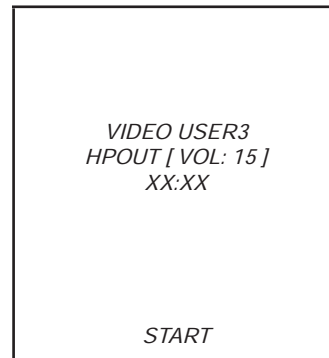

XX:XX : Repetition expert totaling time

5. Press the [BACK] key, return to minor item selection screen.

4-4. Video output (VIDEO OUT)

Note: "VIDEO OUT" must select it never. There is a possibility that the problem occurs in destination setting.

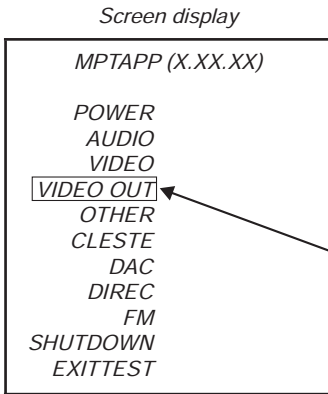

Do not select VIDEO OUT.

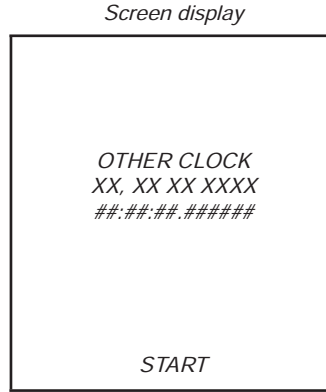

XX, XX XX XXXX : Date
##:##:##:##### : Time

5. Press the [BACK] key, return to minor item selection screen.

4-5. Other (OTHER)

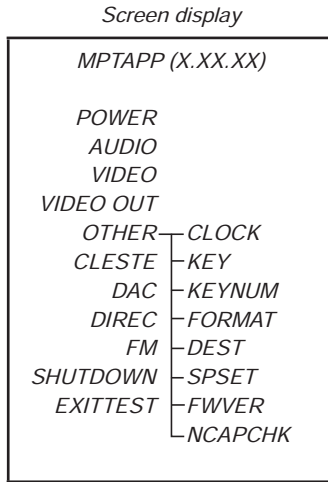

4-5-1. Clock check (CLOCK)

The movement of an internal clock is confirmed.

Checking method:

1. Enter the test mode.
2. Press the [▲]/[▼] keys to select the "OTHER", and press the [▶] key to enter the minor item.
3. Press the [▲]/[▼] keys to select the "CLOCK".
4. Press the [▶||] key, date and time are displayed.
"START" changes into "OK" if the movement of an internal clock is confirmed.

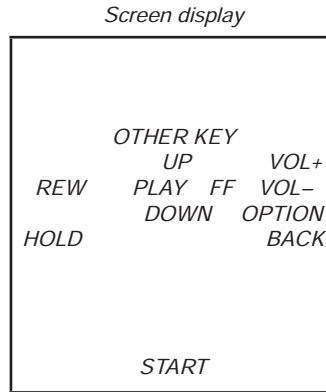

5. The character corresponding to the key is selected every time the key is pressed. "OK" is displayed if all keys are pressed.
6. Slide the [HOLD] key from ON to OFF, return to minor item selection screen.

4-5-3. Frequency check that presses key (KEYNUM)

The frequency to which the key is pressed, insert/pull out frequency of cradle and insert/pull out frequency of the headphone are displayed.

Note: Not used for the servicing.

4-5-4. Format (FORMAT)

The user's area is formatted, and ICV for the video and ICV for audio are initialized.

Note: Not used for the servicing.

Format the set from "Settings" → "Common settings" → "Reset/Format" → "Format" when it home menu in usually operates when the set should format it.

4-5-5. Destination setting (DEST)

The destination setting, language information, and sound pressure regulation information are written in the NAND flash memory.

Note: Not used for the servicing.

4-5-6. Sound pressure regulation setting (SPSET)

ON/OFF of sound pressure regulation is confirmed.

Note: Not used for the servicing.

4-5-7. Firmware version check (FWVER)

The firmware version is displayed.

Checking method:

1. Enter the test mode.
2. Press the [▲]/[▼] keys to select the "OTHER" and press the [▶] key to enter the minor item.
3. Press the [▲]/[▼] keys to select the "FWVER".
4. Press the [▶] key, the firmware version is displayed.

Screen display

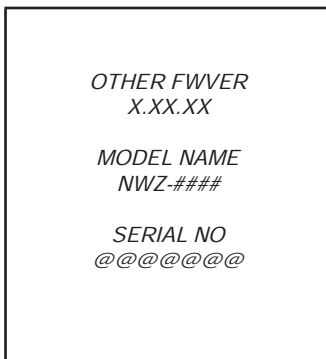

X.XX.XX : Firmware version
 #### : Model name
 @@@@ : Serial No.

5. Press the [BACK] key, return to minor item selection screen.

4-5-8. NAND capacity check (NCAPCHK)

Capacity of NAND flash memory, present bad block, maximum bad block, and vender ID are displayed.

Checking method:

1. Enter the test mode.
2. Press the [▲]/[▼] keys to select the "OTHER", and press the [▶] key to enter the minor item.
3. Press the [▲]/[▼] keys to select the "NCAPCHK".
4. Press the [▶] key, capacity of NAND flash memory, present bad block, maximum bad block, and vender ID are displayed.

Screen display

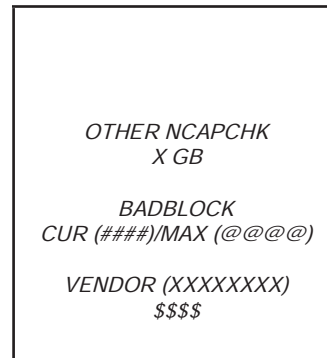

X : Capacity of NAND flash memory
 @@@@ : Number of present bad block
 (It makes an error the acquisition of the number of bad blocks at "-1")
 #### : Number of maximum bud block
 (It makes an error the acquisition of the vender ID at "-1")
 \$\$\$\$: Vender of NAND flash memory

5. Press the [BACK] key, return to minor item selection screen.

4-6. CLESTE

Screen display

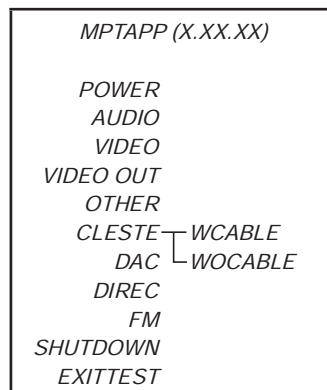

4-6-1. Clear stereo setting (With cable) (WCABLE)

This mode is according to an original sound playback, for adjustment to right and left sound.

Note: Not used for the servicing.

4-6-2. Clear stereo setting (No cable) (WOCABLE)

This mode is according to an original sound playback, for adjustment to right and left sound.

Note: Not used for the servicing.

4-7. DAC

Screen display

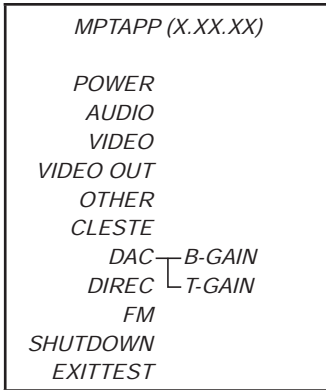

4-7-1. BASS-Gain/Fc setting (B-GAIN)

This mode is adjustment for the sound of BASS when playback.

Note: Not used for the servicing.

4-7-2. TREBLE-Gain/Fc setting (T-GAIN)

This mode is adjustment for the sound of TREBLE when playback.

Note: Not used for the servicing.

4-8. DIREC

Screen display

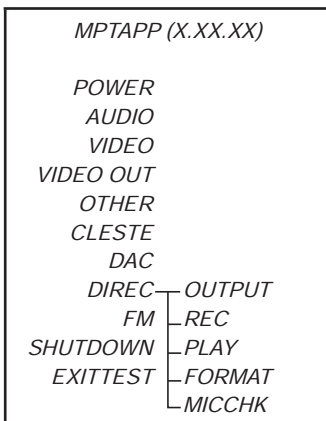

4-8-1. Direct recording output check (OUTPUT)

In this mode, the output confirmation is done.

Checking method:

1. Enter the test mode.
2. Press the [▲]/[▼] keys to select the “DIREC”, and press the [▶] key to enter the minor item.
3. Press the [▲]/[▼] keys to select the “OUTPUT”.
4. Press the [▶||] key, the sound output is begun.

Screen display

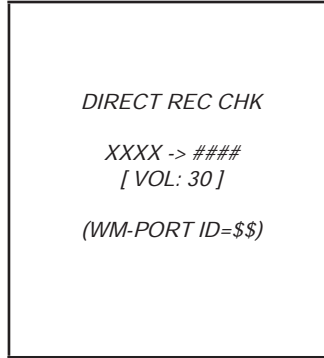

XXXX : Recording cable/cradle connecting state
 ##### : HP/LINE output state
 \$\$: ID of connected device
 20 (When recording cable is connected, or cradle is connected (LINEOUT cable unconnection))
 5 (When cradle is connected (LINEOUT cable connection))

5. Press the [BACK] key, return to minor item selection screen.

4-8-2. Direct recording recording (REC)

In this mode, it records by the format specified in “Direct recording format select”.

Checking method:

1. Enter the test mode.
2. Press the [▲]/[▼] keys to select the “DIREC”, and press the [▶] key to enter the minor item.
3. Press the [▲]/[▼] keys to select the “REC”.
4. Press the [▶||] key, the recording is begun.

Screen display

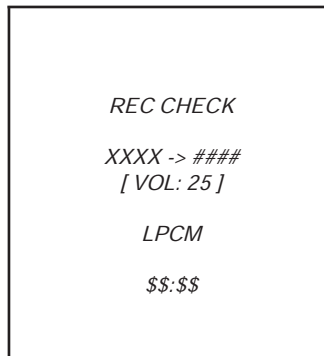

XXXX : Recording cable/cradle/recording microphone connecting state
 ##### : RECODING/STOP state
 \$\$:\$\$: Recording time

5. Press the [BACK] key, return to minor item selection screen.

4-8-3. Direct recording playback (PLAY)

In this mode, the sound recorded in "Direct recording recording" is reproduced.

Checking method:

1. Enter the test mode.
2. Press the [▲]/[▼] keys to select the "DIREC", and press the [▶] key to enter the minor item.
3. Press the [▲]/[▼] keys to select the "PLAY".
4. Press the [▶||] key, the playback is begun.

Screen display

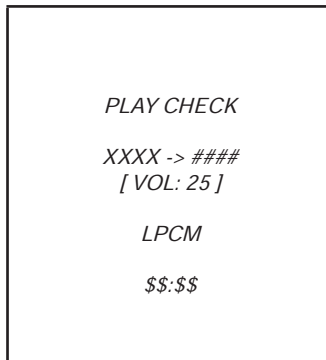

XXXX : PLAYING/STOP state
 #### : HP/LINE output state
 \$\$:\$\$: Playing time

5. Press the [BACK] key, return to minor item selection screen.

4-8-4. Direct recording format select (FORMAT)

In this mode, the recording format is selected.

Note: Not used for the servicing.

4-8-5. Built-in microphone check (MICCHK)

In this mode, the built-in microphone is checked.

Checking method:

1. Enter the test mode.
2. Press the [▲]/[▼] keys to select the "DIREC", and press the [▶] key to enter the minor item.
3. Press the [▲]/[▼] keys to select the "MICCHK".
4. Press the [▶||] key, the built-in microphone check is begun. In this state, the sound that the built-in microphone perceived is outputted from the headphone.

Screen display

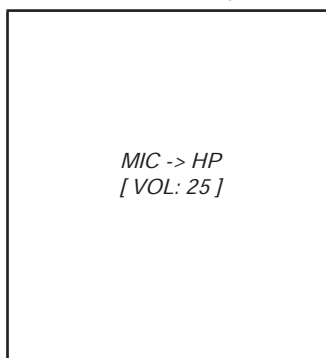

5. Press the [BACK] key, return to minor item selection screen.

4-9. FM

Screen display

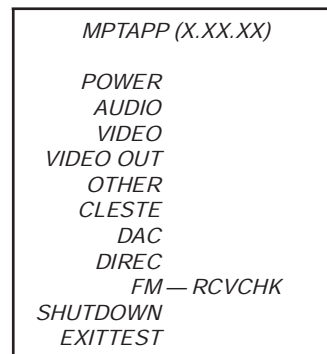

4-9-1. Reception output check (RCVCHK)

FM tuning checked.

Checking method:

1. Enter the test mode.
2. Press the [▲]/[▼] keys to select the "FM", and press the [▶] key to select the "RCVCHK".
3. Press the [▶||] key, "90.00 MHz" is displayed.

Screen display

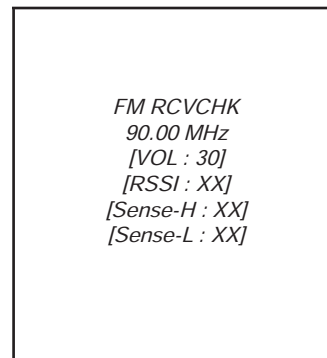

4. In this state, each time the [◀] key is pressed, frequency is changes in the following order.

90.00 MHz (default) → 76.00 MHz → 95.75 MHz → 107.75 MHz → 87.50 MHz → 98.00 MHz → 108.00 MHz → 100.00 MHz

5. In this state, each time the [▶] key is pressed, the LCD back-light brightness is switched.
6. In this state, each time the [OPTION] key is pressed, color bar is displayed.
7. In this state, slide the [HOLD] key from OFF to ON. Each time the [▶]/[◀] keys are pressed, frequency changes in 0.05 MHz.
8. Press the [BACK] key, return to minor item selection screen.

4-10. Shutdown (SHUTDOWN)

Function that power supply of set can be turned off without ending static test mode.

Procedure:

1. Enter the test mode.
2. Press the [▲]/[▼] keys to select the "SHUTDOWN", and press the [▶] key to select the "SURE?".
3. Press the [▶||] key, turn the power off while having entered the test mode.

4-2. CASE (FRONT) SECTION

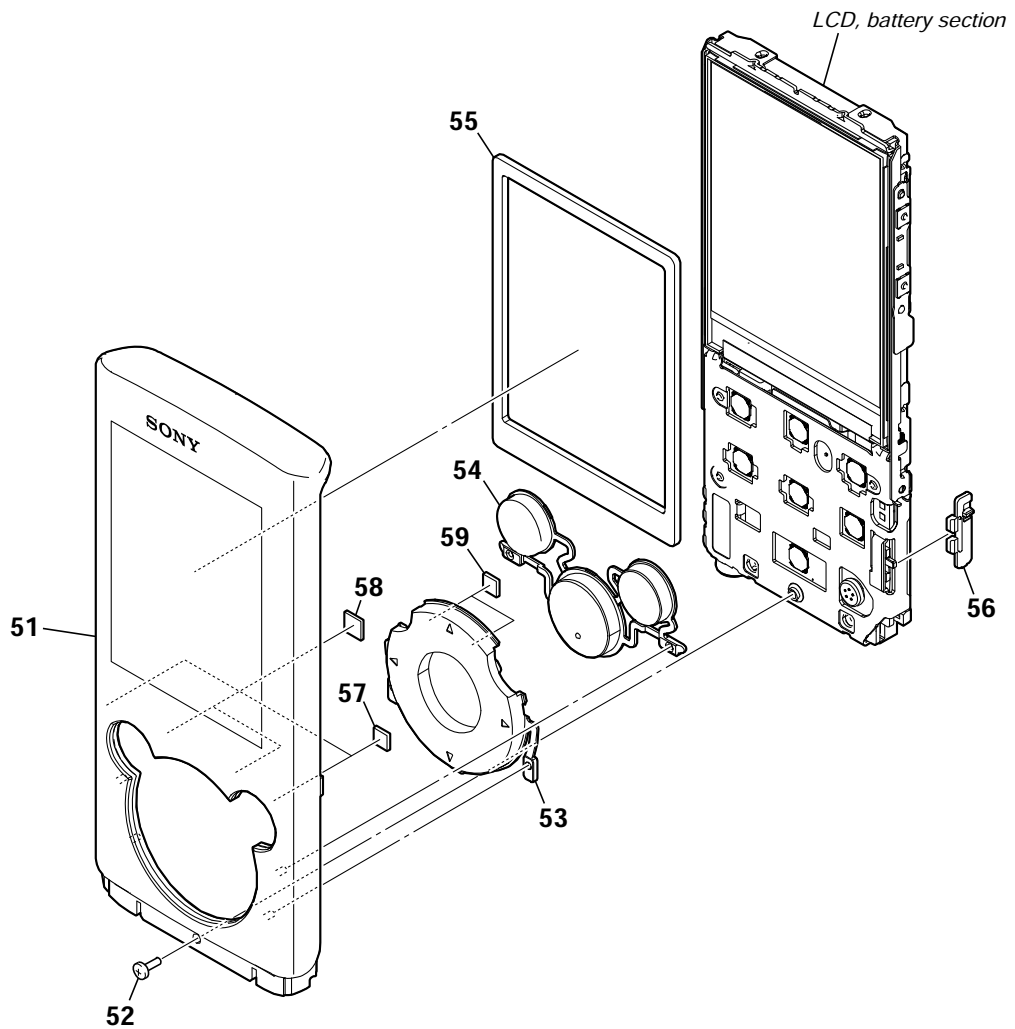

Ref. No.	Part No.	Description	Remark	Ref. No.	Part No.	Description	Remark
51	4-192-425-61	CASE (FRONT) (BLACK)		54	4-192-429-61	BUTTON (PLAY) (BACK, OPTION, ►) (RED)	
51	4-192-425-71	CASE (FRONT) (RED)		54	4-192-429-71	BUTTON (PLAY) (BACK, OPTION, ►) (BLUE)	
51	4-192-425-81	CASE (FRONT) (BLUE)		55	4-195-813-01	CUSHION (LCD)	
52	3-234-449-25	SCREW (M1.4)		56	4-192-435-01	GUIDE (HOLD)	
53	4-192-428-01	BUTTON (4D) (Δ, ▷, ▽, ◁) (BLACK)		57	4-257-827-01	SPACER (CASE FRONT)	
53	4-192-428-61	BUTTON (4D) (Δ, ▷, ▽, ◁) (RED)		58	4-260-100-01	SPACER (CF2)	
53	4-192-428-71	BUTTON (4D) (Δ, ▷, ▽, ◁) (BLUE)		59	4-268-262-01	CUSHION (BUTTON)	
54	4-192-429-01	BUTTON (PLAY) (BACK, OPTION, ►) (BLACK)					

4-3. LCD, BATTERY SECTION

Note 1: This illustration is view from the battery side.

• About Ref. No. 1000

Please cut out and use POLYIMIDE SHEET for a specified size when you exchange it for new parts.

Note 2: As for this part, the material or thickness might be different compared with before. However, there is no obstacle at all.

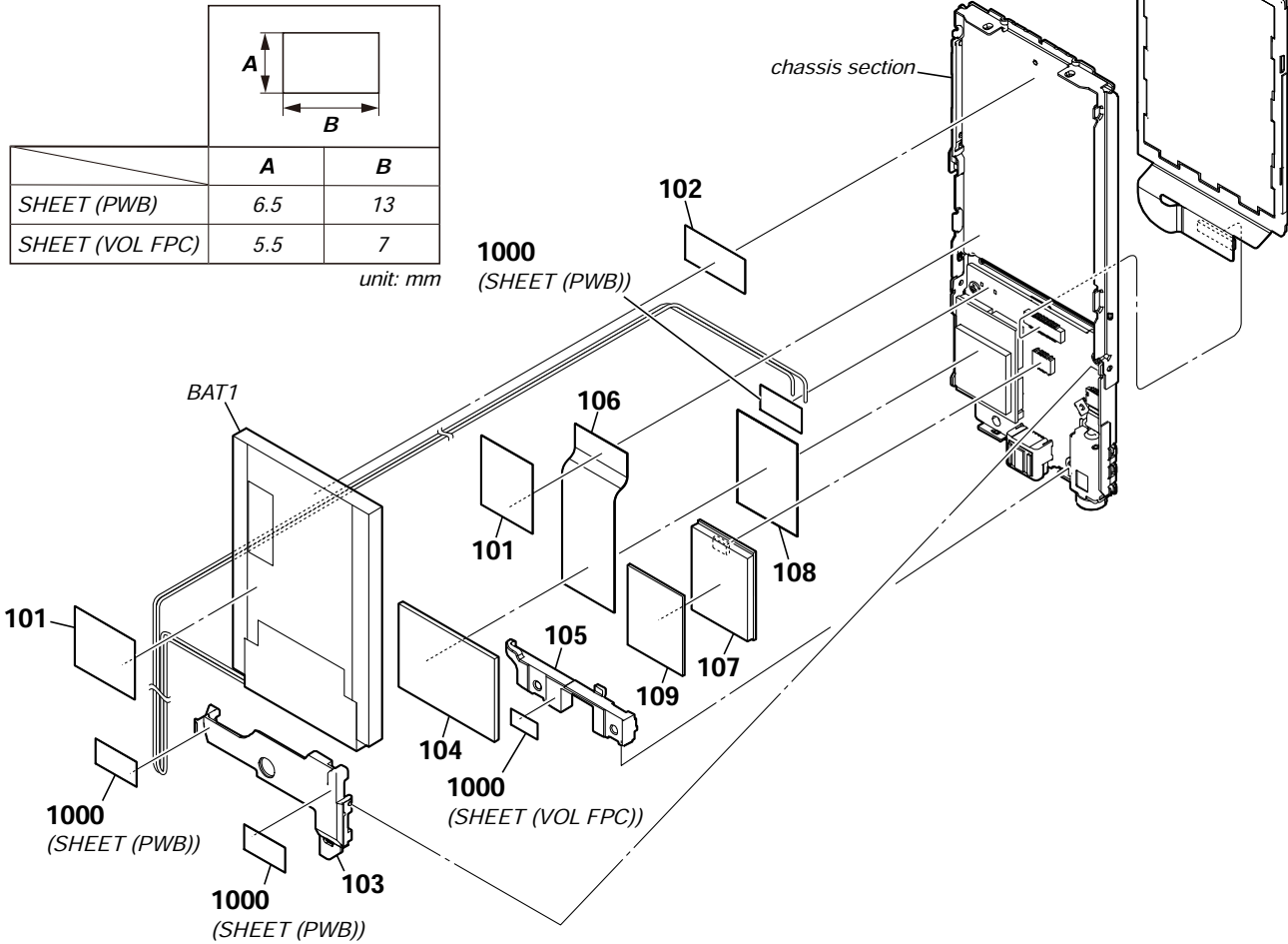

Ref. No.	Part No.	Description	Remark	Ref. No.	Part No.	Description	Remark
101	4-150-173-01	SHEET (WIRE)		107	9-885-147-29	EMMC BOARD, COMPLETE (16GB) (for SERVICE) (NWZ-E355)	
102	4-105-860-01	ADHESIVE, SHEET (BATT)		108	4-257-561-01	SHEET (CORAL) ADHESIVE	
103	4-193-078-01	SUPPORT (M)		109	4-263-096-01	SPACER (NAND)	
104	4-198-386-01	CUSHION (NAND)		1000	9-913-402-43	POLYIMIDE SHEET, t=0.075 (for SERVICE)	
105	4-192-434-01	SUPPORT (MAIN) (RT)		BAT1	X-2546-032-2	SVX BATTERY ASSY	
106	4-208-971-01	LEAF (CORAL), COPPER		LCD1	A-1788-689-A	LCD ASSY	
107	9-885-147-27	EMMC BOARD, COMPLETE (4GB) (for SERVICE) (NWZ-E353)					
107	9-885-147-28	EMMC BOARD, COMPLETE (8GB) (for SERVICE) (NWZ-E354)					

4-4. CHASSIS SECTION

Note 1: This illustration is view from the mother board side.

• **About Ref. No. 1000**

Please cut out and use POLYIMIDE SHEET for a specified size when you exchange it for new parts.

Note 2: As for this part, the material or thickness might be different compared with before. However, there is no obstacle at all.

	A	B
SHEET (CH)	6	6
SHEET (HP FPC)	3	7
SHEET (VOL FPC)	5.5	7

unit: mm

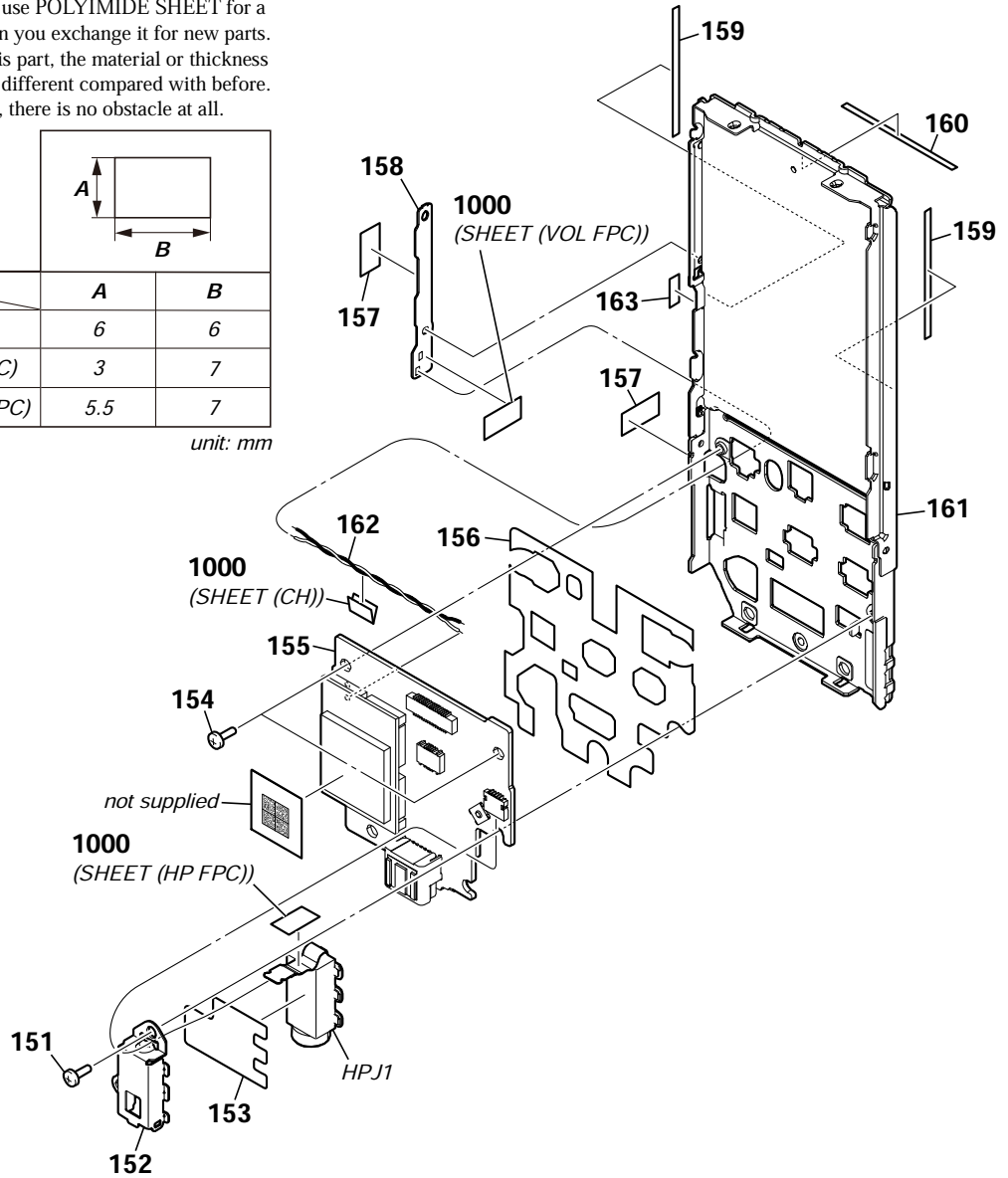

Ref. No.	Part No.	Description	Remark	Ref. No.	Part No.	Description	Remark
151	3-234-449-11	SCREW (M1.4)		159	4-195-814-01	SPACER (LCD)	
152	4-192-466-01	HOLDER (HP)		160	4-195-815-01	SHEET (LCD), ADHESIVE	
153	4-198-036-01	SHEET (HP JACK)		161	X-2548-502-1	CHASSIS ASSY	
154	3-234-449-05	SCREW (M1.4)		162	1-967-566-21	VOL KEY WIRE	
155	9-885-147-23	MOTHER BOARD, COMPLETE (for SERVICE)		163	4-264-851-01	SHEET (FPC), ADHESIVE	
156	4-192-485-01	SHEET (MOTHER)		1000	9-913-402-43	POLYIMIDE SHEET, t=0.075 (for SERVICE)	
157	4-209-153-01	SHEET (CHASSIS)		HPJ1	A-1784-100-A	3PIN HP JACK ASSY	
158	A-1784-102-A	VOL KEY ASSY					

**SECTION 5
ACCESSORIES**

<u>Ref. No.</u>	<u>Part No.</u>	<u>Description</u>	<u>Remark</u>
	1-542-803-11	HEADPHONE (MDR-E804YLP/BC29)	(Headphones)
	1-835-329-11	CORD, CONNECTION (USB5P) (USB cable)	
	4-192-096-11	MANUAL, INSTRUCTION (Quick Start Guide)	(ENGLISH)
	4-192-096-21	MANUAL, INSTRUCTION (Quick Start Guide)	(FRENCH) (Canadian, AEP)
	4-192-096-31	MANUAL, INSTRUCTION (Quick Start Guide)	(RUSSIAN) (East European)
	4-192-096-41	MANUAL, INSTRUCTION (Quick Start Guide)	(UKRAINIAN) (East European)
	4-192-096-51	MANUAL, INSTRUCTION (Quick Start Guide)	(TURKISH) (East European)

MEMO

